

1 2 3 4 5 6 7 8

A  
B  
C  
D  
E  
F

REVISIONS				
ZONE	REV.	DESCRIPTION	DATE	APPROVED
	1	Bläck för jordning tillkom	2017-01-04	Formenta

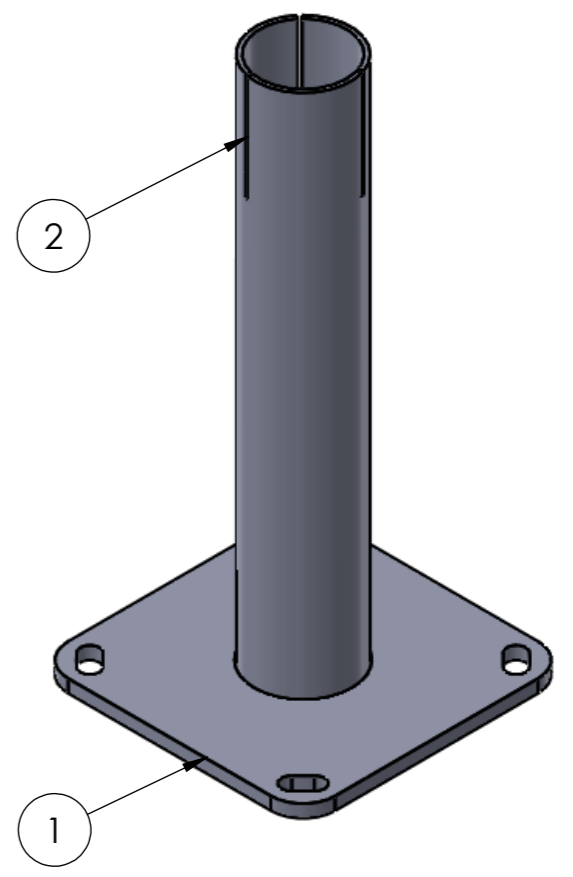
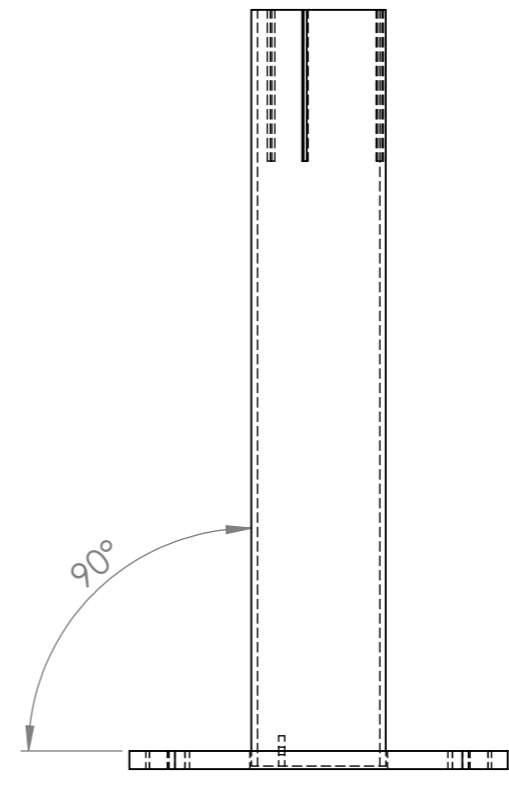
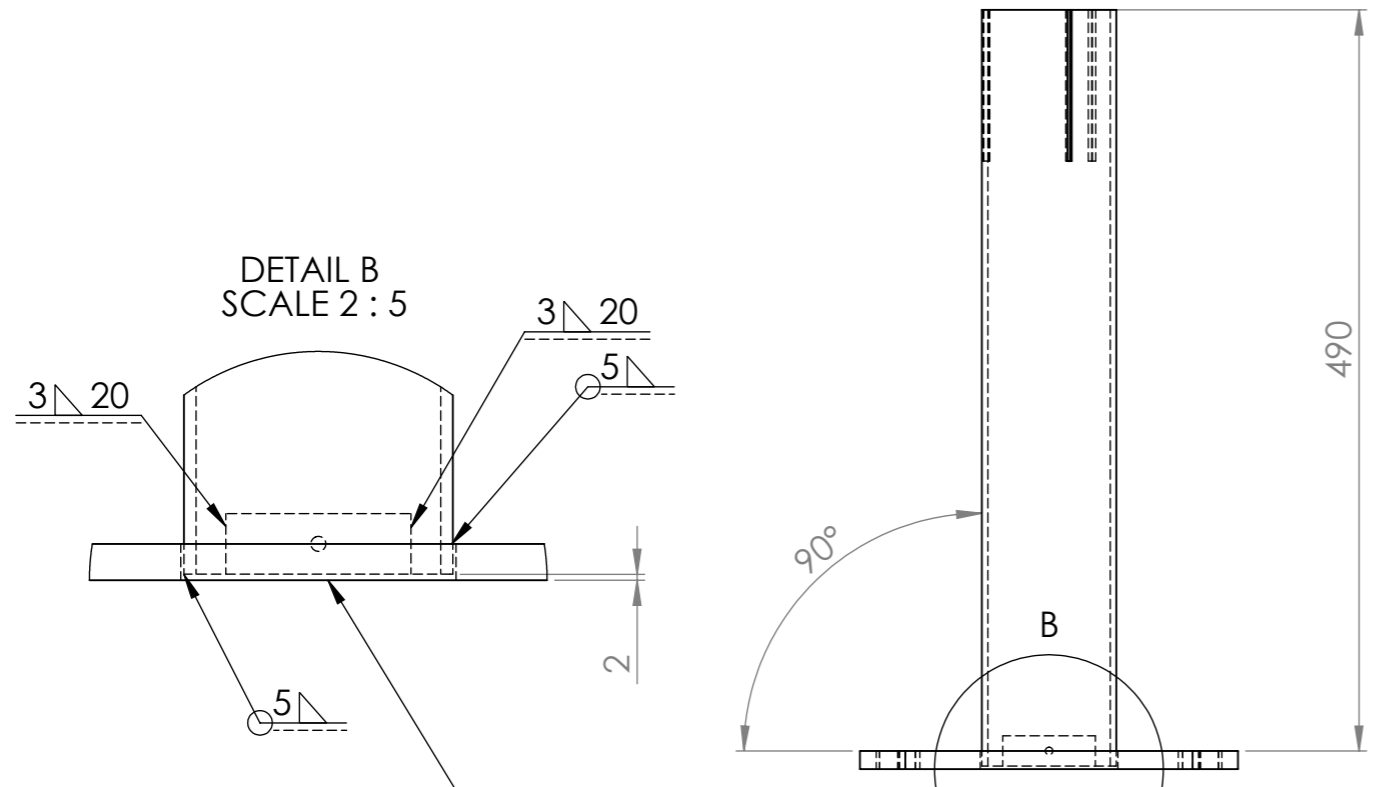

Röret svetsas på både ovan och undersida.  
EJ SVETS UNDER DETTA PLAN.

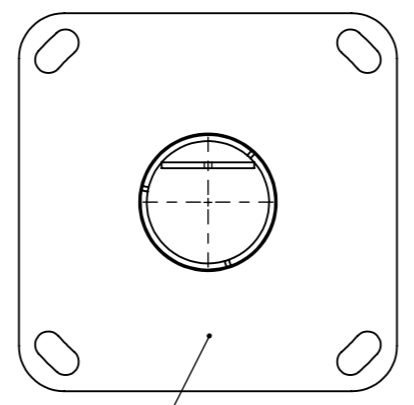

Marked with:  
Manufacturer signature  
Year and week  
As agreed with formenta

Ytbehandling: Galv: SS-EN ISO 1461  
Skarpa kanter bryts

ITEM NO.	PART NUMBER	DESCRIPTION	QTY.
1	300F fotplatta	S235, 12mm	1
2	300F Rör	Rör 88,9x4, S235	1
3	Bläck för jordning	S235, 4mm	1

Konstruerad Av	Ritad Av	Skapad Datum 2015-12-14	Godkänd Av	Generell Tolerans SS ISO 2768-m	Skala 1:5	
Status	Titel / Benämning 300 F					
Agare <b>FORMENTA</b>			Artikel Nr 300-F	Rev	Blad 1 (1)	

This document must not be copied without our written permission, and the contents thereof must not be imparted to a third party nor be used for any unauthorized purpose. Contravention will be prosecuted.

1 2 3 4 5 6 7 8