

A

B

C

D

E

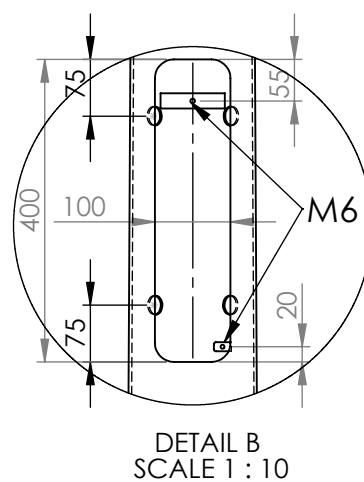
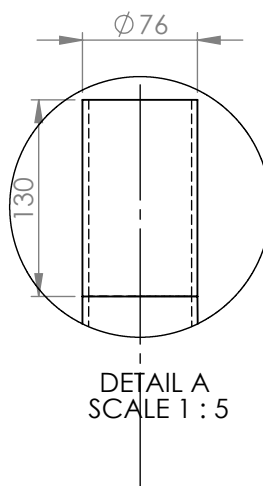
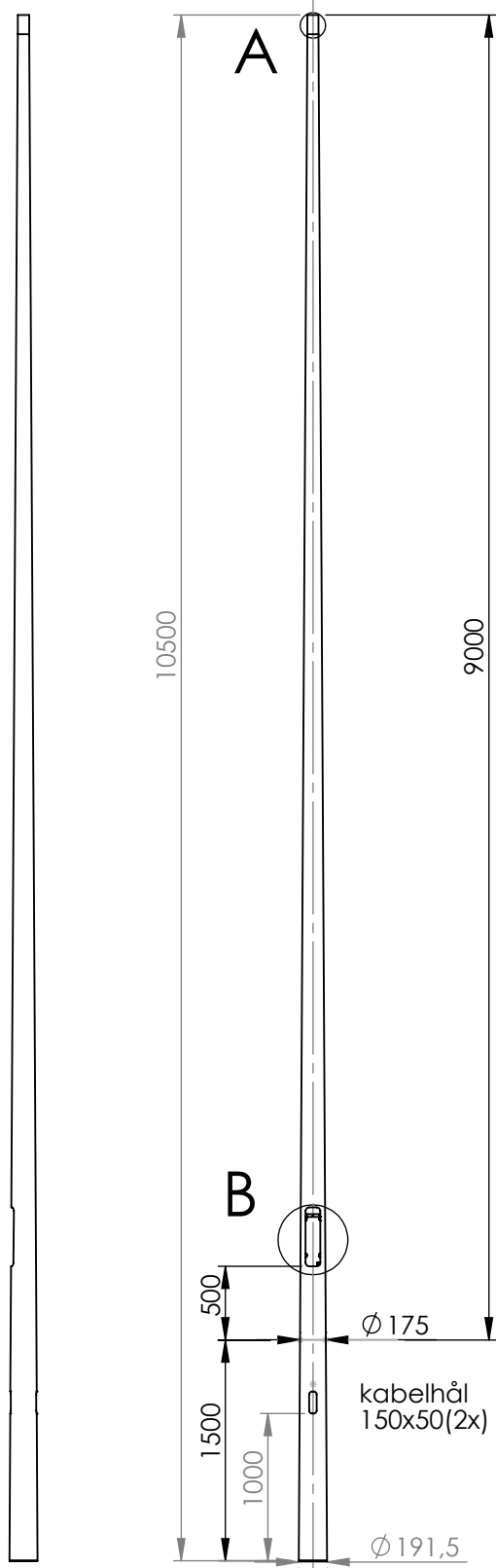

konicitet 11mm/m



| | | | | | | | |
|-----------------|----------------------|-----------|--------------|-----------|--------------------|---|---------------|
| Ritad av: TH | Datum: 2012-03-06 | Godk. av: | Godk./Datum: | Material: | Vikt: 132.29 kg | Tolerans: ISO 2768-1 c Skarpa kanter brutna | Format: A4 |
|-----------------|----------------------|-----------|--------------|-----------|--------------------|---|---------------|

F



Benämning:
KLS 90/76-175 FL

Order:

Skala:
1:50Revision:
A

THIS DRAWING AND ALL OPPURTENANT MATTER SHALL REMAIN THE COMPANY MORA MAST AB PROPERTY. THEY SHALL NOT WITHOUT OUR WRITTEN PERMISSION, EITHER IN THEIR ORIGINAL STATE OR WITH ANY CHANGES BE COPIED OR MANIFOLDED. SHOWN TO OR IN ANY OTHER WAY COMMUNICATED TO OR HANDED OVER TO ANY PART.

Ritningsnummer:
7781872

Blad:
1/1