

1

2

3

4

A

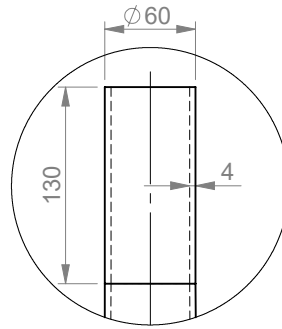
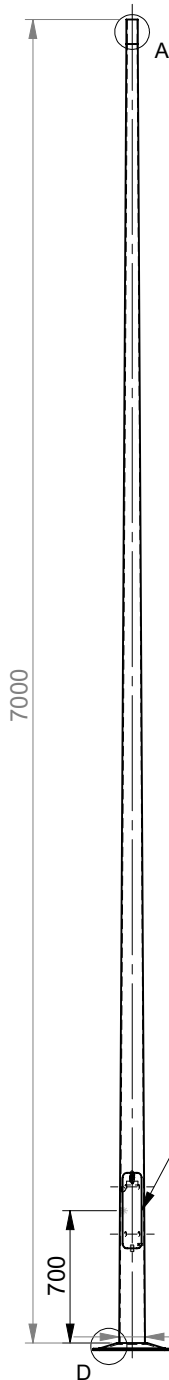

DETAIL A
SCALE 1 : 5

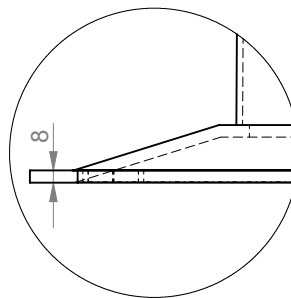

DETAIL D
SCALE 1 : 5

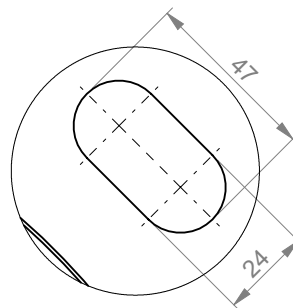

DETAIL C
SCALE 1 : 2



Konicitet 11 mm/m

D

E

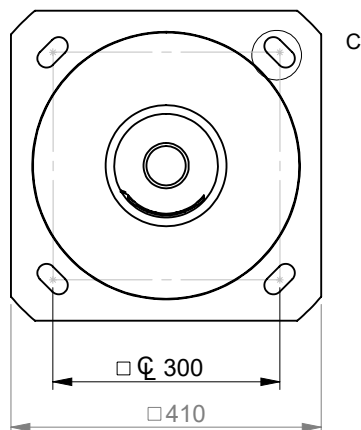

Skarpa kanter brutna

F

| | | | | | | | | |
|-----------------|----------------------|-----------------|----------------------------|-----------|---------------------|-------------------|---------------------------|----------------|
| Ritad av: TH | Datum: 2010-12-16 | Godk. av: SA | Godk./Datum: 2016-05-13 | Material: | Status: Released | Vikt: 73.69 kg | Tolerans: ISO 2768-1 c | Skala: 1:40 |
|-----------------|----------------------|-----------------|----------------------------|-----------|---------------------|-------------------|---------------------------|----------------|

moramast

This drawing and all oppurtenant matter shall remain the company Mora Mast AB property. They shall not without our written permission, either in their original state or with any changes be copied or manifolded, shown to or in any other way communicated to or handed over to any part.

Benämning:
KLS 70/60-137-4 FP

Ritningsnr:
7781833

Rev:
A

Format:
A4

Blad:
1/1