

E-nr. **7780786** Benämning. **MM-SH120 E0**

Vz	RL	L	Dy1	Dy2	Db	lucka
X	X	12000	152,4	60,3	100	7781910

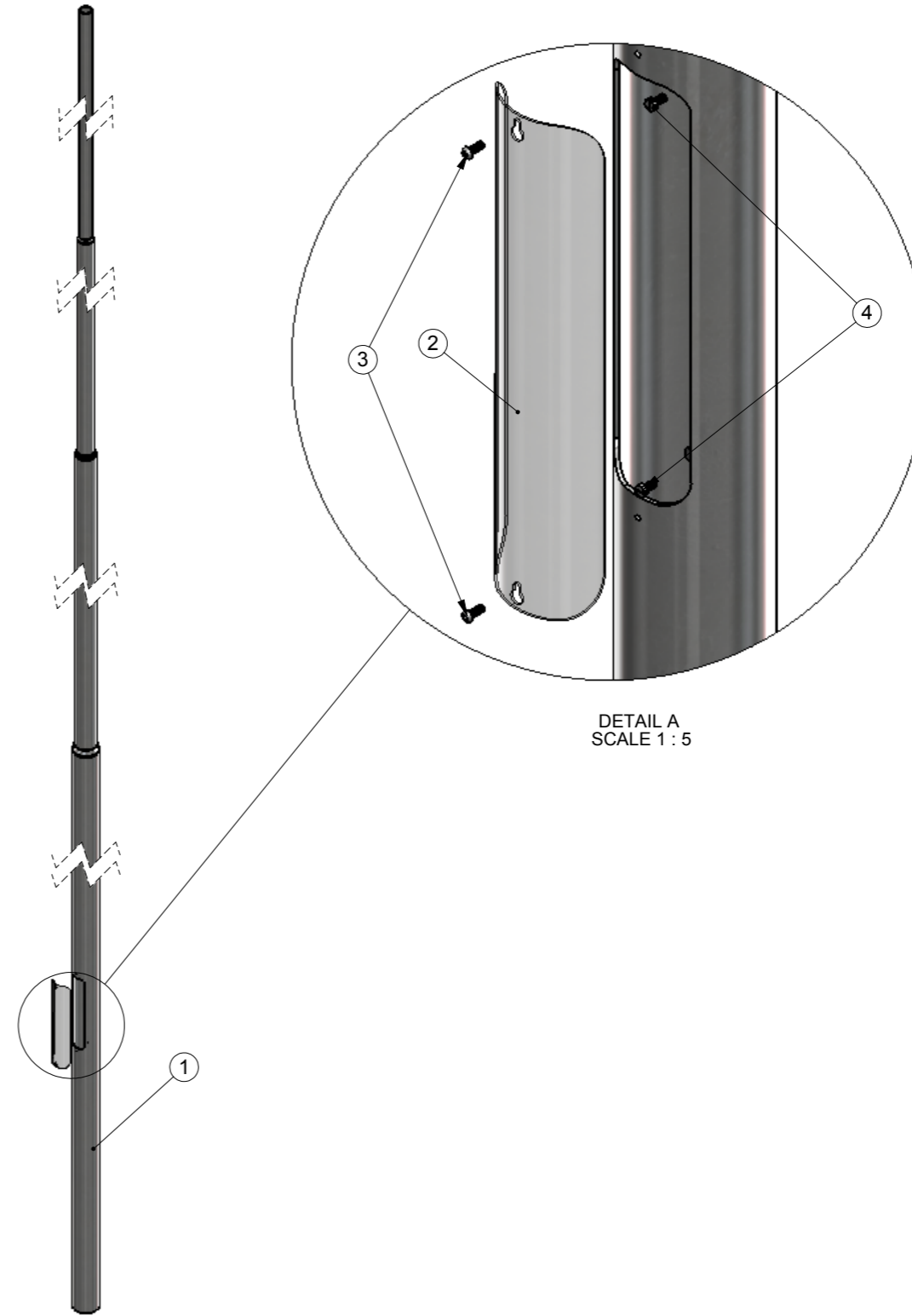
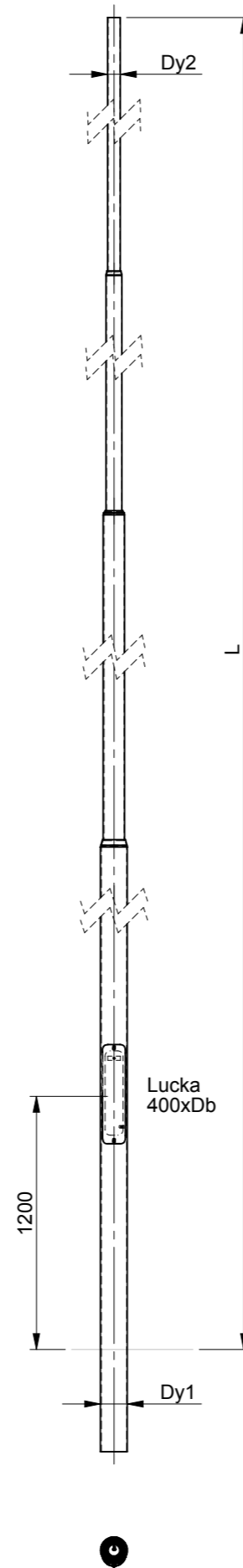

No	Qty	Description	Part No	Material
1	1	Rörsektioner Dy & L se tabellritn.	MM-S-2-ST	
2	1	Lucka se tabell	se tabell	S235JRG2 (1.0038)
3	2	Skruv K6S M6x16 M6S A2	2001	S2333 rost fritt
4	2	Skruv MCS M6x12 A2	2002	S2333 rost fritt

Ritad av: TH Datum: 2012-07-04 Godk. av: Godk./Datum: Material: Status: Draft Vikt: 90.62 kg Tolerans: ISO 2768-1 c Skala: 1:30

**moramast**

This drawing and all appurtenant matter shall remain the property of Mora Mast AB. They shall not be copied, reproduced, or otherwise disseminated without the written permission of Mora Mast AB. Any changes to this drawing shall be communicated to or handed over to any party.

Benämning: **MM-S-2 STUKADE 6-12M**  
Ritningsnr: **MM-S-2-SAMMANST.STUKAT**

Rev: - Blad: 1/1