

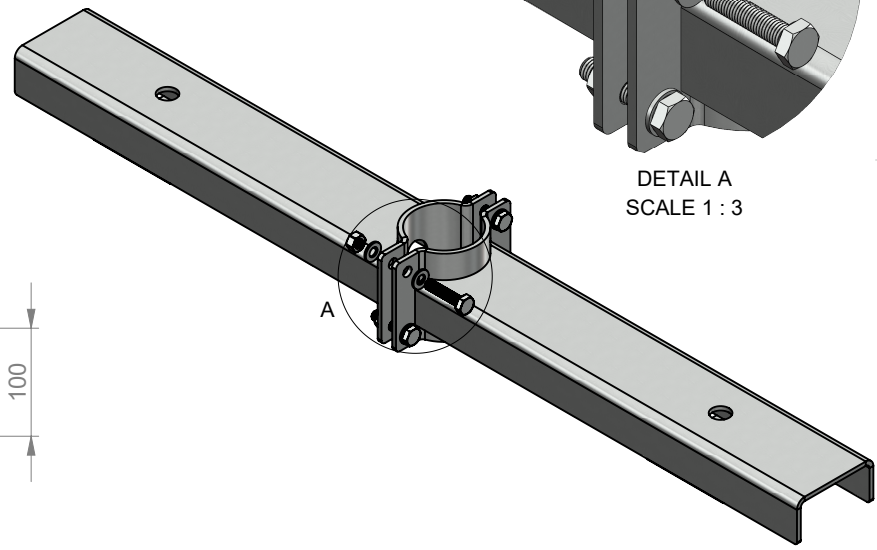

DETAIL A
SCALE 1 : 3



Skarpa kanter brutna

Ritad av: MM	Datum: 2019-12-10	Godk. av: SA	Godk./Datum: 2020-11-02	Material:	Status: Released	Vikt: 9.02 kg	Tolerans: ISO 2768-1 c	Skala: 1:7
					Benämning: Strålkastarbalk 2A L500 T76		Format: A4	
					Ritningsnr: 7780080	Rev: A	Blad: 1/1	

This drawing and all oppurtenant matter shall remain the company Mora Mast AB property. They shall not without our written permission, either in their original state or with any changes be copied or manifolded, shown to or in any other way communicated to or handed over to any part.