

Stoppkruvar dolda i denna vy

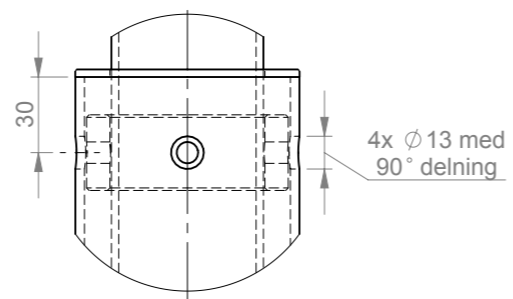

DETAIL I
SCALE 1 : 3

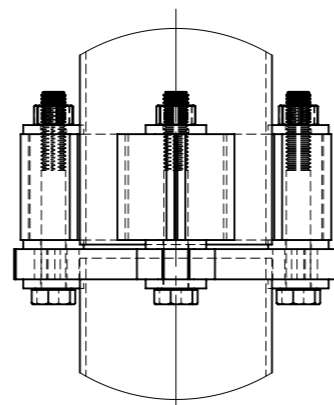

DETAIL H
SCALE 1 : 5

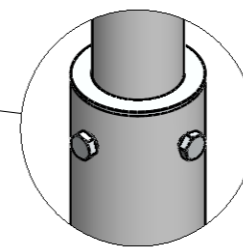

DETAIL E
SCALE 1 : 5

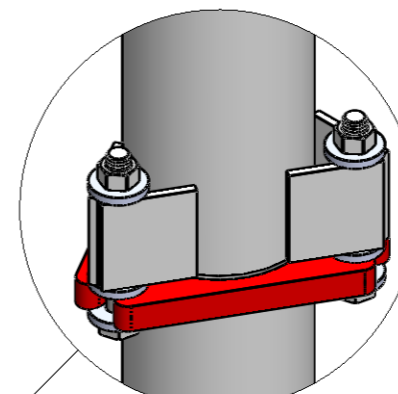

DETAIL F
SCALE 1 : 5

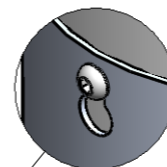

DETAIL G
SCALE 1 : 2

M16 skruvar momentdras 130Nm efter färdig stolpe

Ritad av:	Datum:	Godk. av:	Godk./Datum:	Material:	Status:	Vikt:	Tolerans:	Skala:
MM	2015-09-08	SA	2015-09-08		Released	97.30 kg	ISO 2768-1 c	1:35
Skarpa kanter brutna					Benämning:		Format:	
					MMSH80 D20 G2		A3	
					Ritningsnr:		Blad:	
					7775117		1/1	
					Rev:		A	



This drawing and all appurtenant matter shall remain the property of Mora Mast AB. They shall not be copied or reproduced in any form without the written permission of Mora Mast AB. Any changes to this drawing shall be communicated to or handed over to any part.

Benämning:
MMSH80 D20 G2

Ritningsnr:
7775117

Rev:
A

Skala:
1:35
Format:
A3
Blad:
1/1