

## CONVENTIONAL - Rate of Rise Thermal Detector Model ECO1005 A

### Overview

#### Features

- Low profile design
- Low current draw
- 58°C operating temperature
- Operates on 12 and 24VDC
- Remote alarm test feature
- Easy Maintenance
- Range of detector bases available
- Remote LED Option
- Approved to EN54 – 5:2000 Class A2S
- Approved to MED 96/98/EC (Amendment 2009/26/EC)
- Extended warranty



199n/06



G201073

0832-MED-1019  
0832-MED-1020

### Description

The ECO1005T A thermal detector belongs to System Sensor's ECO1000 range of detectors. ECO1000 is a range of conventional detectors, which have been produced using the latest in manufacturing technology and supplied with an array of advanced features, making them 'better by design'.

The ECO1005T A thermal detector uses a state of the art thermal element combined with an application specific integrated circuit (ASIC) to provide quick and accurate detection of fires. The detector incorporates a static element and is suitable where ambient conditions normally exhibit rapid changes in temperature e.g. kitchens.

A laser-based hand held Remote Test Unit can be used in conjunction with the range of ECO1000 detectors for alarm test purposes. The unit transmits a coded message, preventing spurious alarms being generated by other laser-based devices. With a range of several metres, the hand held test unit provides an effortless way of remotely alarm testing the range of ECO1000 detectors and removes the need for any direct physical access to the detector by the user.

The ECO1005T A detector also has an integral LED, which illuminates to provide a local alarm signal. This latches on, and remains illuminated until the detector is reset by a momentary power interruption. An optional remote LED annunciator may be used to repeat any alarm signal.

A variety of detector bases can be used with the ECO1005T A detector, providing application flexibility and compatibility with a wide range of Fire Alarm Control Panels. All bases are fitted with a shorting spring to permit circuit testing prior to fitting the detector and have a tamper resistant feature, which when activated prevents removal of the detector without the use of a tool.

All System Sensor products are covered by our extended 3-year warranty.

# Architect/Engineer Specifications

ECO1005T A 58°C Fixed Temperature Thermal Detector

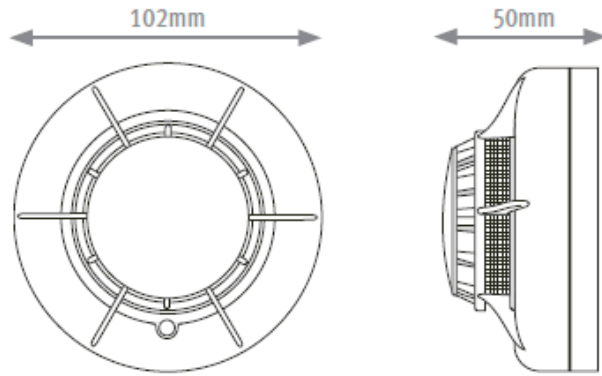

## Electrical Specifications

Operating Voltage Range	8 to 30VDC (Nominal 12/24VDC)
Maximum Standby Current @ 25°C	70µA @ 24VDC
Maximum Permissible Alarm Current	80mA (current limited by control panel)

## Environmental Specifications

Application Temperature Range (see note)	-30°C to +70°C
Humidity	0 to 95% Relative Humidity (non condensing)

## Mechanical Information

Height	40.5mm (plus 9.5mm for standard base, 21mm for deep base)
Diameter	102mm
Weight	70g (plus 45g for standard base)
Wire Gauge for Terminals	0.4mm <sup>2</sup> to 2.0mm <sup>2</sup>
Colour	Approximates to RAL9016
Material	ABS

## Product Range

Bases (see note)	
ECO1000B Standard Base	ECO1000BSD Standard base with Shottky diode
ECO1000BR Resistor base 470 Ohm	ECO1000BRSD Resistor base 470 Ohm with Shottky diode
ECO1000DB Deep base	ECO1000DBSD Deep base with Shottky diode
ECO1000DBR Deep resistor base 470 Ohm	ECO1000DBRSD Deep resistor base 470 Ohm with Schottky diode
ECO1000BREL12L Relay base 12V Latching	ECO1000BREL12NL Relay base 12V Non –latching
ECO1000BREL24L Relay base 24V Latching	
Accessories	
ECO1000RTU Remote Test Unit	
Other Detectors	
ECO1002 A Photoelectric/Thermal Detector	ECO1003 A Photoelectric Detector
ECO1004T A 78°C Fixed Temperature Thermal Detector	ECO1005 A Rate of Rise & 58°C Fixed Temperature Thermal Detector

### Notes

Bases with other resistor values are available to suit the requirements of most Fire Alarm Control Panels.



# WEEE/RoHS/REACH Assessment

ECO1005T A Product Evaluation Record

## General information

Manufacturing Location	System Sensor Trieste Pittway tecnologica S.r.l. Via Caboto 19/3 34147 Trieste, Italy
Model Numbers	ECO1005T A
Product description	THERMAL DETECTOR ECO1000 SERIES
Product Life Cycle	Life span expectancy of >20 years (assuming that environmental conditions have been taken into consideration and the modules are regularly maintained)

## Material Content

Name of Part	Material	RoHS	Hazardous	Recycling Instruction (WEEE is out of scope)
Dust cover	polystyrene	Yes	Non-hazardous	Re-used or recycled
Cover thermal/photo thermal	ABS	Yes	Non-hazardous	Recycled by regrinding into granules and blending with virgin material or landfilled
Swirl chamber cover	ABS; PC+ABS - FR	Yes	Non-hazardous	Recycled or landfilled
Swirl chamber base	ABS+Stirene- Etilene-Butilene- Stirene (SEBS); ABSFR+ Stirene- Etilene-Butilene- Stirene (SEBS)	Yes	Non-hazardous	Not recyclable - landfilled
Light pipe	PMMA	Yes	Non-hazardous	Re-used or recycled
Cover	ABS	Yes	Non-hazardous	Re-used or recycled
Printed Circuit Board	CEM3 (Epoxy,Glass) SAC305 (Copper Coating, Solder)	Yes	Non-hazardous	Recycled or landfilled
Printed Circuit Board Components	Metals, Plastics, Ceramics, Tin Stainless Steel, Tin Brass	Yes	Non-hazardous	Recycled or landfilled

## Energy Consumption

ECO1005T A	
Avg. Standby Power	1,32 mW (55 µA at 24 V) at 25°C one communication every 5 sec. With LED blink enabled
Max. Alarm Power (LED on)	1,92 W (80mA at 24VDC)

## Environmental Permit

System Sensor Trieste Facility (address as above) approved to ISO 14001. These products do not require an environmental permit.

## Packaging

Primary packaging	Single Box: Cardboard
Secondary packaging	Masterbox (5 Singlebox per M.box) and Shippingbox ( 28 M.box per S.box): cardboard, Tape (polypropylene)
Transportation packaging	Pallet (wooden platform), wrapping (polyethylene 04)

## Additional Information

The purpose of this report is to provide information on the environmental aspects of the product, emphasis being on the material content and the energy consumption. Since there are not any emissions of harmful substances during the use of this product or in the manufacturing process of it, it is not necessary to specify these factors in this report. Also the transportation emissions are not included.

## System Sensor (Technical Services)

System Sensor Europe  
Unit C2  
Foundry Lane, Horsham, West Sussex  
RH13 5YZ, UK  
Tel: +44 (0)1403 330240  
Fax: +44 (0)1403 330695  
Email: sse.technical@systemsensor.com  
www.systemsensoreurope.com

## System Sensor Europe (Customer Services)

Life Safety Distribution GmbH  
Javastrasse 2, 8604 Hegnau  
Switzerland  
Tel: 0041 44 943 4400  
Email: orders@systemsensor.com  
www.systemsensoreurope.com