

®

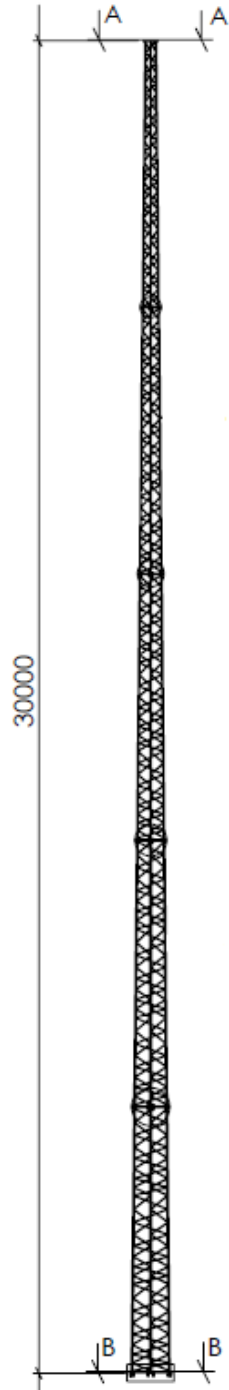

SECTION A-A
SCALE 1 : 15

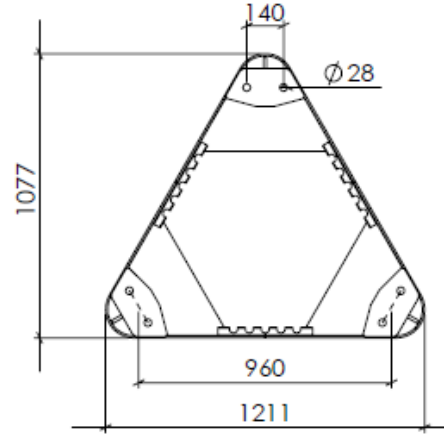
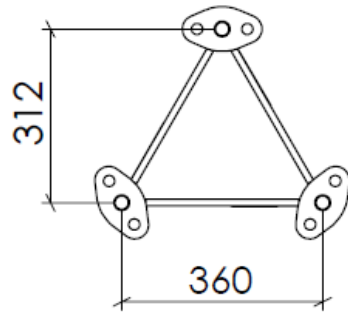

SECTION B-B
SCALE 1 : 20

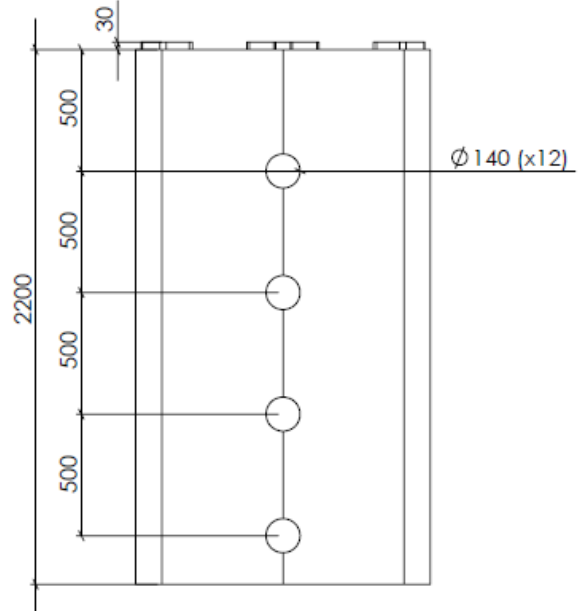
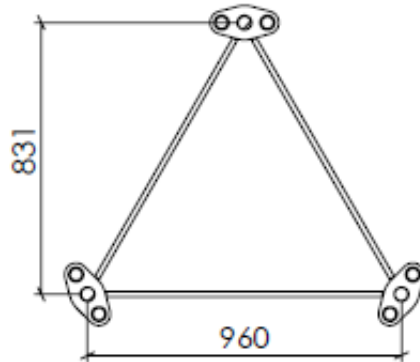

960 - 360			
Terräng	1	2	3
	m2	m2	m2
26 m/s	0,79	1,16	1,70
25 m/s	0,99	1,36	1,89
24 m/s	1,21	1,53	2,1
23 m/s	1,43	1,70	2,34

Z Mast 30 960/360	Högmast ¹	Fundament ¹	Tillbehör/Montage
E-nummer	7781024	7781005	Se övriga tillbehör
Artikelnummer	4G2-13	3M3-06	Se övriga tillbehör
Masten är dimensionerad och beräknad utifrån Säkerhetsklass 3			
 AB VARMFÖRZINKNING	¹ Sektionerna varmförzinkas enligt SS-EN 1461 Fe/Zn 115 CE-märkt enligt EN-1090-1:2009+A1:2011, 0402-CPR-SC0989-16		

Företaget är certifierat i förekommande fall enligt:
ISO 9001, ISO 3834-2, EN 1461, EN 1090

www.varmförzinkning.se tel. 0371-34300



2023-01-16