

SECTION A-A
SCALE 1 : 15

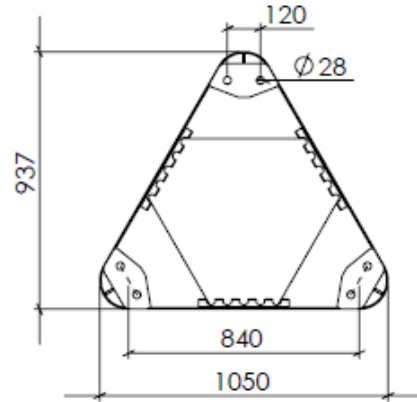

SECTION B-B
SCALE 1 : 20

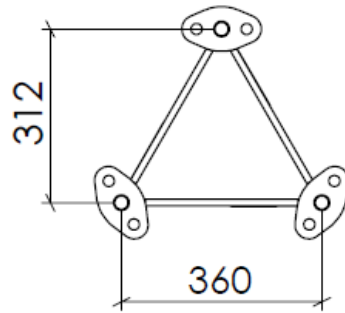
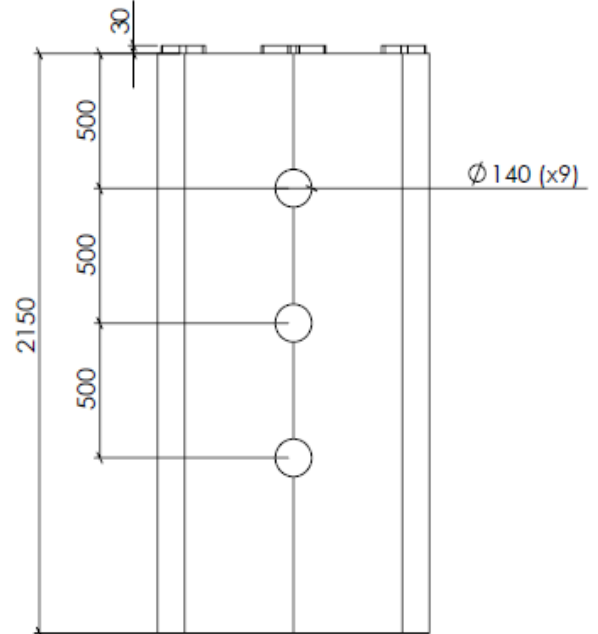
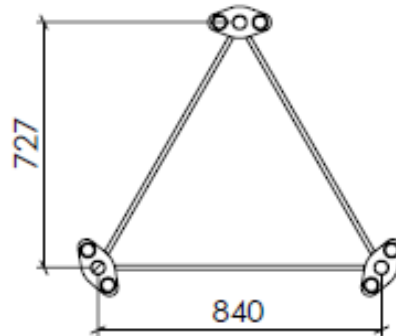

840 - 360			
Terräng	1	2	3
	m2	m2	m2
26 m/s	1,04	1,28	1,84
25 m/s	1,18	1,43	2,03
24 m/s	1,31	1,59	2,25
23 m/s	1,49	1,77	2,50

Z Mast 24 840/360	Högmast ¹	Fundament ¹	Tillbehör/Montage
E-nummer	7781022	7781004	Se övriga tillbehör
Artikelnummer	4G2-10	3M3-05	Se övriga tillbehör

Masten är dimensionerad och beräknad utifrån Säkerhetsklass 3

 AB VARMFÖRZINKNING	¹ Sektionerna varmförzinkas enligt SS-EN 1461 Fe/Zn 115 CE-märkt enligt EN-1090-1:2009+A1:2011, 0402-CPR-SC0989-16		
---------------------------------------------------------------------------------------------------------------	----------------------------------------------------------------------------------------------------------------------------------	--	--

Företaget är certifierat i förekommande fall enligt:
 ISO 9001, ISO 3834-2, EN 1461, EN 1090

www.varmförzinkning.se tel. 0371-34300



2023-01-16