

SECTION A-A  
SCALE 1 : 15

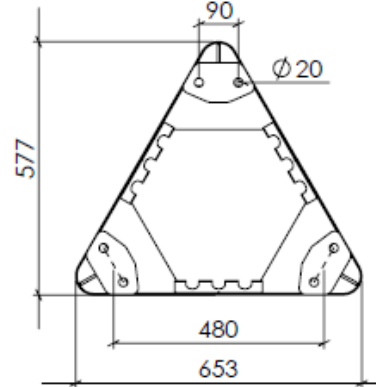

SECTION B-B  
SCALE 1 : 12

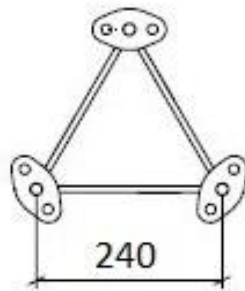
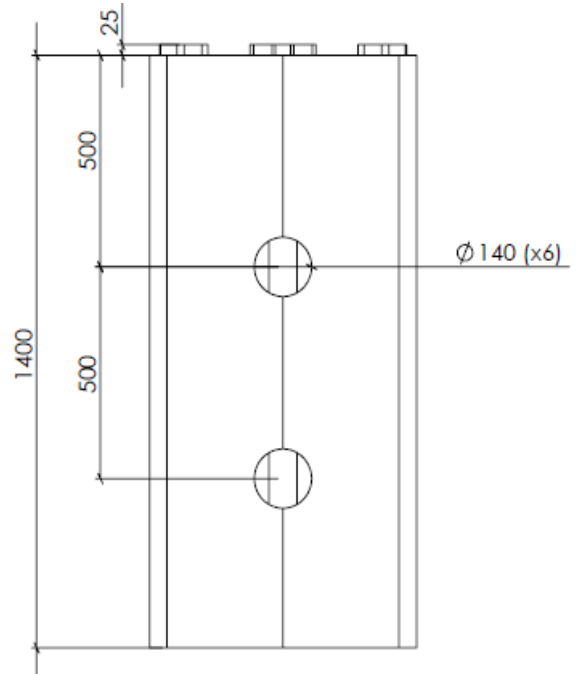
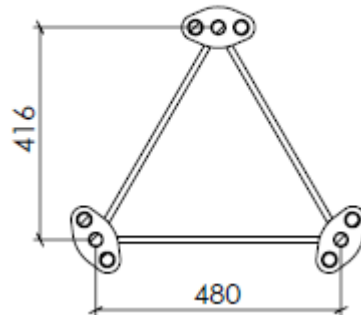

480 - 240			
Terräng	1	2	3
	m2	m2	m2
26 m/s	0,12	0,24	0,50
25 m/s	0,18	0,29	0,60
24 m/s	0,24	0,36	0,69
23 m/s	0,30	0,45	0,79

<b>Z Mast 15 480/240</b>	Högmast <sup>1</sup>	Fundament <sup>1</sup>	Tillbehör/Montage
<b>E-nummer</b>	7781013	7781001	Se övriga tillbehör
<b>Artikelnummer</b>	4G2-03	3M3-02	Se övriga tillbehör

Masten är dimensionerad och beräknad utifrån Säkerhetsklass 3

 <b>AB VARMFÖRZINKNING</b>	<sup>1</sup> Sektionerna varmförzinkas enligt SS-EN 1461 Fe/Zn 115 CE-märkt enligt EN-1090-1:2009+A1:2011, 0402-CPR-SC0989-16	
---	--	--

Företaget är certifierat i förekommande fall enligt:  
 ISO 9001, ISO 3834-2, EN 1461, EN 1090

www.varmförzinkning.se tel. 0371-34300



2023-01-16