

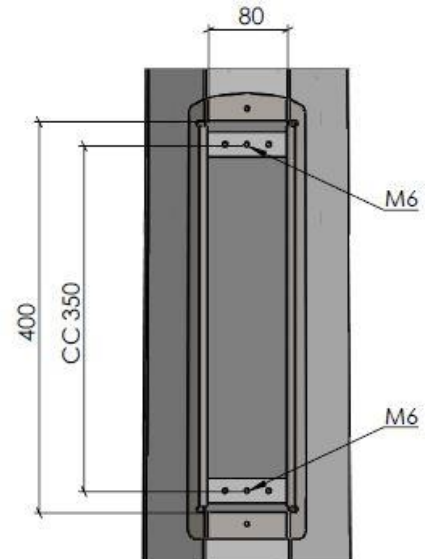

AB VARMFÖRZINKNING

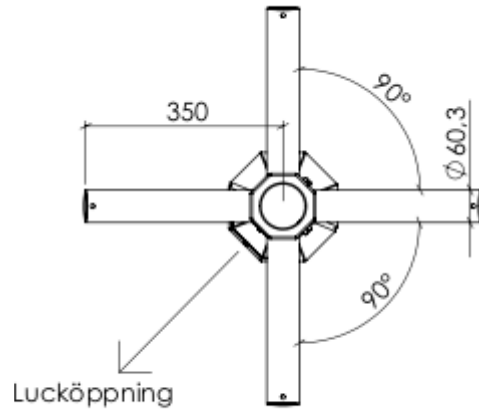

Vind ref.	Terrängtyp			
	II		III	
	Kg	m ²	Kg	m ²
26 m/s	20	0,17	23	0,26
25 m/s	22	0,21	26	0,3
24 m/s	25	0,25	30	0,34
Max belastning per armatur				
Partiallastfaktor klass A				

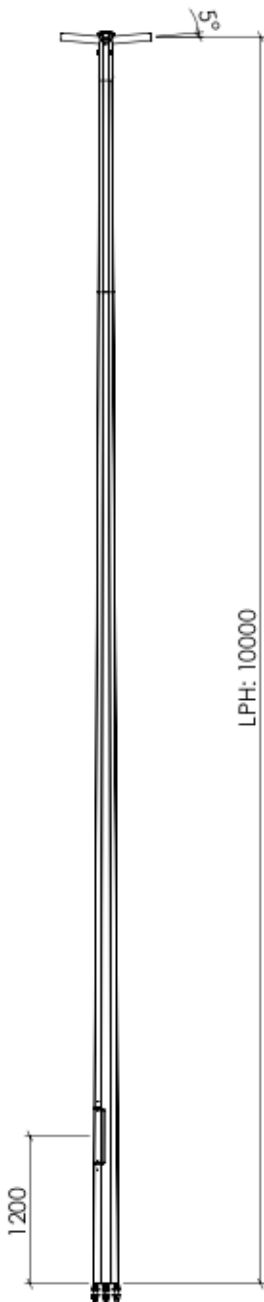
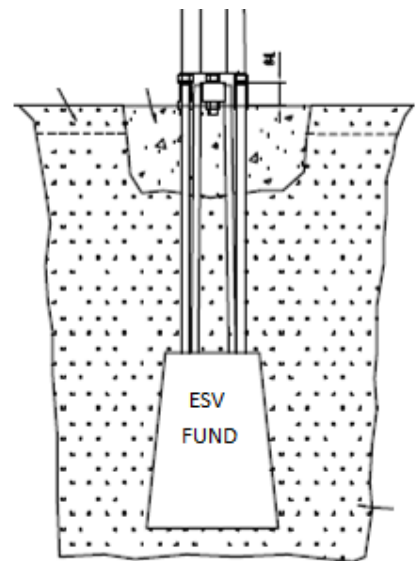

Z ESV 10 4 0,3 RL	Rotlack ¹	Hellack ¹	Eftergivlig 100 HE1 EN 12767
E-nummer	7776429	n/a	
Art. nummer	ESES-24-16	ESES-24-45	
Fund rek.	7778544	7778544	
Fäste armatur	60mm	Lutning arm	5°
AB VARMFÖRZINKNING	¹ Stolparna varmförzinkas enligt SS-EN 1461 Fe/Zn 115 CE-märkt enligt EN-40 No.0402 – CPD- SC0381-13		

Företaget är certifierat i förekommande fall enligt:
ISO 9001, ISO 3834-2, EN 1461 mfl.

www.varmförzinkning.se tel. 0371-34300



2019-02-05