

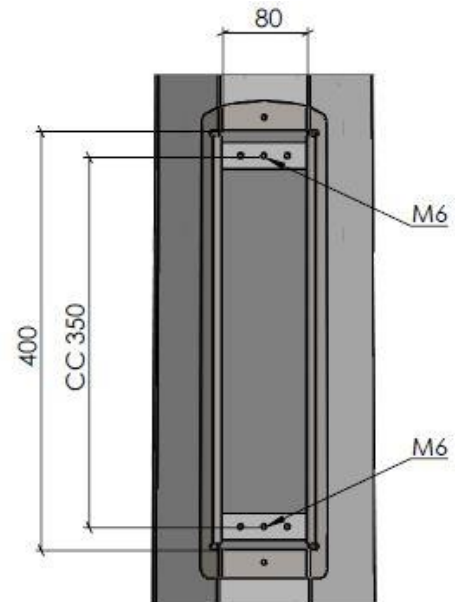

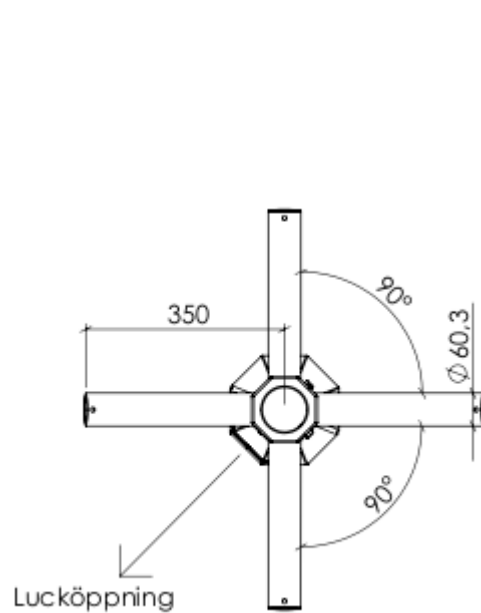

## AB VARMFÖRZINKNING

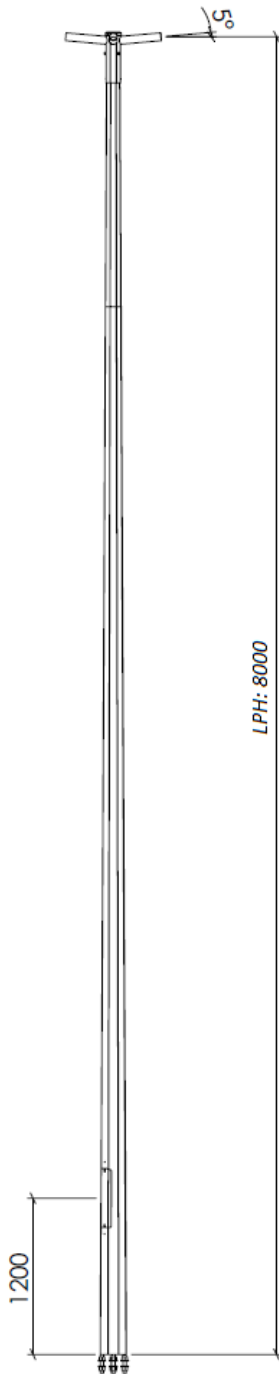
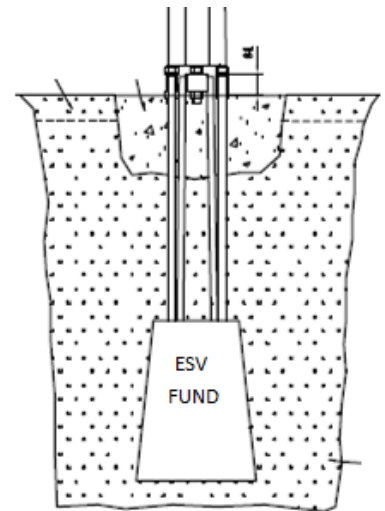

Vind ref.	Terrängtyp			
	II		III	
	Kg	m <sup>2</sup>	Kg	m <sup>2</sup>
26 m/s	23	0,22	32	0,32
25 m/s	25	0,25	36	0,35
24 m/s	26	0,27	37	0,38
Max belastning per armatur				
Partiellastfaktor klass A				



Z ESV 8 4 0,3 RL	Rotlack <sup>1</sup>	Hellack <sup>1</sup>	Eftergivlig 100 HE1 EN 12767
E-nummer	7776419	n/a	
Art. nummer	ESES-24-13	n/a	
Fund rek.	7778542	7778542	
Fäste armatur	60mm	Lutning arm	5°
 AB VARMFÖRZINKNING	<sup>1</sup> Stolparna varmförzinkas enligt SS-EN 1461 Fe/Zn 115 CE-märkt enligt EN-40 No.0402 – CPD- SC0381-13		

Företaget är certifierat i förekommande fall enligt:  
ISO 9001, ISO 3834-2, EN 1461 mfl.

www.varmförzinkning.se tel. 0371-34300



2019-01-17