

- 1 Suitable for surfaces 1 - 3mm (.04" - .12") thick

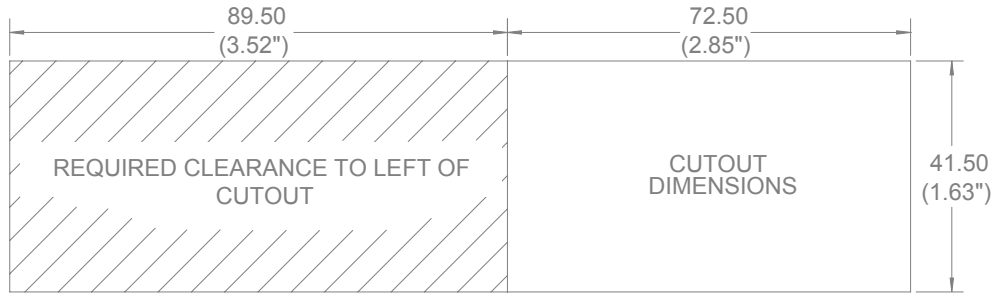

- 2 Attach power cable to QF15 TUF HP and then feed the power cable into panel, then insert QF15 TUF HP at an angle as shown

NOTE: If there is no access to rear, a minimum of 45mm (1.77") clearance is required

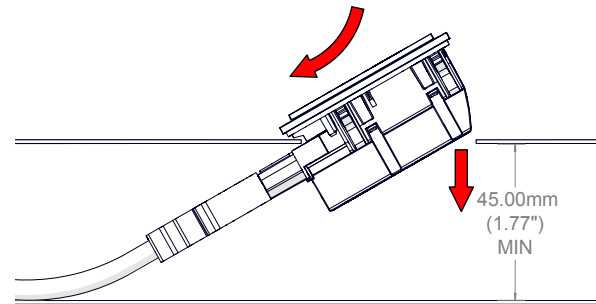
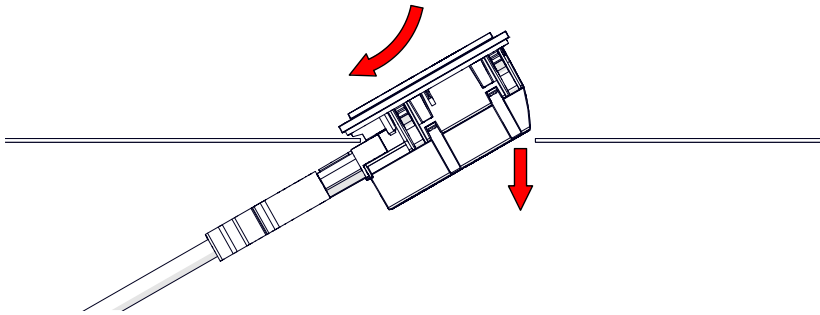

- 3 Apply equal pressure across the front of the QF15 TUF HP until it clicks into place

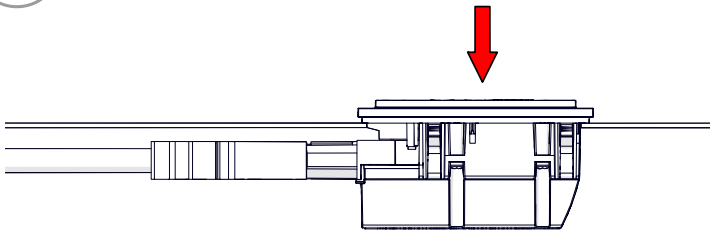

- 4 Alternatively, if rear access is available QF15 TUF HP can be fitted into the panel first (as above with 35mm (1.38") clearance required), and then the GST18i3 cable attached afterwards

