

GOODWE



User Manual

Hybrid Inverter

ET Series

15-30kW

V1.2-2023-02-28

Copyright©GoodWe Technologies Co., Ltd. All rights reserved.

No part of this manual can be reproduced or transmitted to the public platform in any form or by any means without the prior written authorization of GoodWe Technologies Co.,Ltd.

Trademarks

GOODWE and other GOODWE trademarks are trademarks of GoodWe Technologies Co.,Ltd. All other trademarks or registered trademarks mentioned in this manual are owned by GoodWe Technologies Co.,Ltd.

Notice

The information in this user manual is subject to change due to product updates or other reasons. This manual cannot replace the product safety labels unless otherwise specified. All descriptions here are for guidance only.

CONTENT

1	About This Manual	1
1.1	Applicable Model	1
1.2	Target Audience	1
1.3	Symbol Definition	2
1.4	Updates	2
2	Safety Precaution	3
2.1	General Safety	3
2.2	PV String Safety	3
2.3	Inverter Safety	4
2.4	Battery Safety	5
2.5	Personnel Requirements	5
2.6	EU Declaration of Conformity	5
3	Product Introduction	6
3.1	Product Overview	6
3.2	Application Scenarios	7
3.3	Working Mode	9
3.3.1	System Working Mode	9
3.3.2	Inverter Operation Mode	14
3.4	Features	15
3.5	Appearance	17
3.5.1	Parts	17
3.5.2	Dimension	17
3.5.3	Indicators	18
3.5.4	Nameplate	19
4	Check and Storage	20
4.1	Check Before Receiving	20
4.2	Deliverables	20
4.3	Storage	21
5	Installation	22
5.1	Installation Requirements	22
5.2	Inverter Installation	25
5.2.1	Moving the Inverter	25
5.2.2	Installing the Inverter	25
6	Electrical Connection	27
6.1	System Wiring Diagram	27
6.2	Safety Precaution	29
6.3	Connecting the PE cable	29

6.4	Connecting the DC Input Cable(PV)	30
6.5	Connecting the battery cable	32
6.6	Connecting the AC Cable	34
6.7	Communication Connection	35
6.7.1	Connecting the Communication Cable (Terminal Block)	37
6.7.2	Connecting the Communication Cable (RJ45 Connector)	38
6.7.3	Connecting the BMS or Meter Communication Cable.....	39
6.7.4	Installing the Communication Module (Optional).....	40
7	Equipment Commissioning	41
7.1	Check Before Power ON.....	41
7.2	Power On	41
8	System Commissioning.....	42
8.1	Indicators and Buttons	42
8.2	Setting Inverter Parameters via SolarGo App	43
8.3	Monitoring via SEMS Portal	43
9	Maintenance	44
9.1	Power OFF the Inverter	44
9.2	Removing the Inverter	44
9.3	Disposing of the Inverter	44
9.4	Troubleshooting.....	45
9.5	Routine Maintenance.....	53
10	Technical Parameters.....	54

1 About This Manual

This manual describes the product information, installation, electrical connection, commissioning, troubleshooting, and maintenance. Read through this manual before installing and operating the product. All the installers and users have to be familiar with the product features, functions, and safety precautions. This manual is subject to update without notice. For more product details and latest documents, visit <https://en.goodwe.com>.

1.1 Applicable Model

This manual applies to the listed inverters below:



Model	Nominal Output Power	Nominal Output Voltage
GW15K-ET	15000W	380/400V, 3L/N/PE
GW20K-ET	20000W	
GW25K-ET	25000W	
GW29.9K-ET	29900W	
GW30K-ET	30000W	

1.2 Target Audience

This manual applies to trained and knowledgeable technical professionals. The technical personnel has to be familiar with the product, local standards, and electric systems.

1.3 Symbol Definition

Different levels of warning messages in this manual are defined as follows:

 DANGER
Indicates a high-level hazard that, if not avoided, will result in death or serious injury.
 WARNING
Indicates a medium-level hazard that, if not avoided, could result in death or serious injury.
 CAUTION
Indicates a low-level hazard that, if not avoided, could result in minor or moderate injury.
NOTICE
Highlights key information and supplements the texts. Or some skills and methods to solve product-related problems to save time.

1.4 Updates

The latest document contains all the updates made in earlier issues.

V1.3 2023-08-31

- Updated 4.2 Deliverables
- Updated 5.2.2 Installing the Inverter
- Updated 6.5 Connecting the Battery Cable
- Updated 6.7.3 Connecting the BMS or Meter Communication Cable

V1.2 2023-02-28

- Updated Technical Parameters

V1.1 2022-11-30

- Updated Appearance description
- Updated Deliverables

V1.0 2022-08-30

- First Issue

2 Safety Precaution

Please strictly follow these safety instructions in the user manual during the operation.

NOTICE

The inverters are designed and tested to strictly comply with related safety rules. Read and follow all the safety instructions and cautions before any operations. Improper operation might cause personal injury or property damage as the inverters are electrical equipment.

2.1 General Safety

NOTICE

- The information in this user manual is subject to change due to product updates or other reasons. This manual cannot replace the product safety labels unless otherwise specified. All descriptions here are for guidance only.
- Before installations, read through the user manual to learn about the product and the precautions.
- All operations should be performed by trained and knowledgeable technicians who are familiar with local standards and safety regulations.
- Use insulating tools and wear personal protective equipment when operating the equipment to ensure personal safety. Wear anti-static gloves, clothes, and wrist strips when touching electronic devices to protect the inverter from damage.
- Strictly follow the installation, operation, and configuration instructions in this manual. The manufacturer shall not be liable for equipment damage or personal injury if you do not follow the instructions. For more warranty details, please visit <https://en.goodwe.com/warranty>.

2.2 PV String Safety



DANGER

Connect the DC cables of the inverter to the included DC terminals. Severe damage might happen if other types of DC terminals are used, which are beyond the manufacturer's liability.



WARNING

- Ensure the component frames and the bracket system are securely grounded.
- Ensure the DC cables are connected tightly, securely and correctly.
- Measure the DC cables with a multimeter to avoid reverse polarity connection. Also, the voltage should be under the permissible range.
- Do not connect one PV string to more than one inverter at the same time. Otherwise, it may damage the inverter.
- The PV modules used with the inverter must have an IEC61730 class A rating.









2.3 Inverter Safety

 **WARNING**

- The voltage and frequency at the connecting point should meet the on-grid requirements.
- Additional protective devices like circuit breakers or fuses are recommended on the AC side. Specification of the protective device should be at least 1.25 times the maximum AC output current.
- Make sure that all the groundings are tightly connected. When there are multiple inverters, make sure that all the grounding points on the enclosures are equipotential bonding.
- The alarm can be cleared automatically if the inverter triggers a fault for less than 5 times within 24 hours. The inverter will shutdown for protection after the 5th electric arc fault. The inverter can operate normally after the fault is solved.
- BACK-UP is not recommended if the PV system is not configured with batteries. Otherwise, the risk in system power usage is beyond the equipment manufacturer's warranty scope.

 **DANGER**

- All labels and warning marks should be visible after the installation. Do not cover, scrawl, or damage any label on the equipment.
- Warning labels on the inverter are as follows:

	<p>DANGER High voltage hazard. Disconnect all incoming power and turn off the product before working on it.</p>		<p>Delayed discharge. Wait 5 minutes after power off until the components are completely discharged.</p>
	<p>Read through the user manual before any operations.</p>		<p>Potential risks exist. Wear proper PPE before any operations.</p>
	<p>High-temperature hazard. Do not touch the product under operation to avoid being burnt.</p>		<p>Grounding point.</p>
	<p>CE certification mark</p>		<p>Do not dispose of the inverter as household waste. Discard the product in compliance with local laws and regulations, or send it back to the manufacturer.</p>

2.4 Battery Safety

WARNING

- The battery used with the inverter shall be approved by the inverter manufacturer. The approved battery list can be obtained through the official website.
- Before installations, read through the corresponding battery's user manual to learn about the product and the precautions. Strictly follow its requirements.
- If the battery discharged completely, please charge it in strict accordance with the corresponding model's user manual.
- Factors such as: temperature, humidity, weather conditions, etc. may limit the battery's current and affect its load.
- Contact after-sale service immediately if the battery is not able to be started. Otherwise, the battery might be damaged permanently.
- Use the multimeter to measure the DC cable to avoid reverse polarity connection. Also, the voltage should be under the permissible range.
- Do not connect one battery pack to more than one inverter at the same time. Otherwise, it may cause damage to the inverter.

2.5 Personnel Requirements

NOTICE

- Personnel who install or maintain the equipment must be strictly trained, learn about safety precautions and correct operations.
- Only qualified professionals or trained personnel are allowed to install, operate, maintain, and replace the equipment or parts.

2.6 EU Declaration of Conformity

GoodWe Technologies Co., Ltd. hereby declares that the inverter with wireless communication modules sold in the European market meets the requirements of the following directives:

- Radio Equipment Directive 2014/53/EU (RED)
- Restrictions of Hazardous Substances Directive 2011/65/EU and (EU) 2015/863 (RoHS)
- Waste Electrical and Electronic Equipment 2012/19/EU
- Registration, Evaluation, Authorization and Restriction of Chemicals (EC) No 1907/2006 (REACH)

GoodWe Technologies Co., Ltd. hereby declares that the inverter without wireless communication modules sold in the European market meets the requirements of the following directives:

- Electromagnetic compatibility Directive 2014/30/EU (EMC)
- Electrical Apparatus Low Voltage Directive 2014/35/EU (LVD)
- Restrictions of Hazardous Substances Directive 2011/65/EU and (EU) 2015/863 (RoHS)
- Waste Electrical and Electronic Equipment 2012/19/EU
- Registration, Evaluation, Authorization and Restriction of Chemicals (EC) No 1907/2006 (REACH)

You can download the EU Declaration of Conformity on <https://en.goodwe.com>.

3 Product Introduction

3.1 Product Overview

Intended usage

Inverters control and optimize the power in PV systems through an integrated energy management system. The power generated in the PV system can be used, stored in the battery, output to the utility grid, etc.

Model

This manual applies to the listed inverters below:

- GW15K-ET
- GW20K-ET
- GW25K-ET
- GW29.9K-ET
- GW30K-ET

Model description

GW15K-ET



No.	Referring to	Explanation
1	Brand Code	GW: GoodWe
2	Rated Power	15K: the rated power is 15000W.
3	Series Code	ET: ET series three-phase hybrid inverter

Supported Grid Types

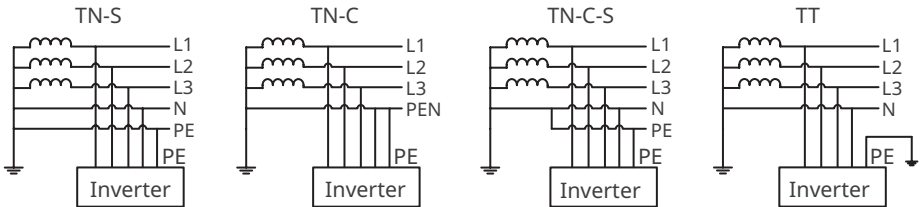

3.2 Application Scenarios

WARNING

- The PV system is not suitable to connect equipment that relies on a stable power supply, such as medical equipment to sustain life. Ensure that no personal injury is occurred when the system is disconnected.
- Avoid loads with high start-up current like high-power water pumps in the PV system. Otherwise, the off-grid output may fail due to excessive instantaneous power.
- BACK-UP is not recommended if the PV system is not configured with batteries. Otherwise, the risk in system power usage is beyond the equipment manufacturer's warranty scope.
- Factors such as: temperature, humidity, weather conditions, etc. may limit the battery's current and affect its load.
- If a rapid shutdown (RSD for short) module is configured in a PV system, make sure that the RSD module matches the integrated RSD transmitter in the inverter, and if not, the shutdown function may fail.
- When single overload protection occurs, the inverter can restart automatically; however, the restarting time will be extended if it happens several times. For a faster restarting, try it via APP .
- When the grid is disconnected, the off-grid function of the inverter will be closed automatically if the load capacity exceeds the inverter's rated power. To enable it, turn off the large loads and ensure the load power is less than the rated power of the inverter.
- Nomral household loads can be supported when the inverter is in back-up mode. Accepted loads as below:
 - Inductive loads: 1.5P non-inverter air conditioner can be connected to the inverter. If two or more non-inverter air conditioners are connected, the back-up mode may be unstable.
 - Capacitive load: total power ≤ 0.66 times of the inverter's rated output power.
 - Do not connect three-phase motor loads without N wires.

Self consumption mode

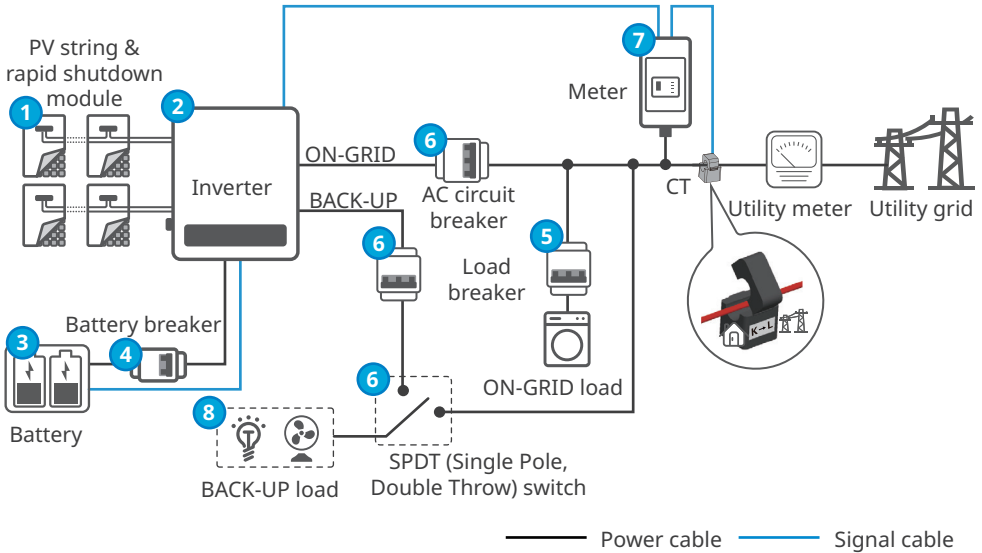

No.	Parts	Description
1	PV string & rapid shutdown module	Rapid shutdown function is optional. An external RSD module is required to shut down the equipment rapidly. You can purchase the module from the inverter manufacturer, or choose the AP RSD-D-XX series or AP Tigo TS4 series. More information about the RSD module can be obtained from the packing box.
2	Inverter	Supports ET 15 -30kW series inverters.
3	Battery	The battery used with the inverter shall be approved by the inverter manufacturer. The approved battery list can be obtained through the official website.
4	Battery breaker	Recommended specifications: nominal current \geq 63A, nominal voltage \geq 1000V.
5	Load Breaker	Depend on the actual using load.
6	AC circuit breaker and SPDT switch	Recommended specifications: <ul style="list-style-type: none"> GW15K-ET: nominal current\geq32A, nominal voltage\geq400V GW20K-ET: nominal current\geq40A, nominal voltage\geq400V GW25K-ET: nominal current\geq50A, nominal voltage\geq400V GW29.9K/30K-ET: nominal current\geq63A, nominal voltage\geq400V
7	Smart meter	The smart meter is delivered with the inverter or purchased from the inverter manufacturer. Recommended model: GM3000.
8	BACK-UP loads	<ul style="list-style-type: none"> Connecting BACK-UP loads, such as loads requiring 24-hour power supply or other important loads. Connecting unbalanced loads. L1, L2, L3 of the inverter respectively connected to loads with different power. Do not connect three-phase motor loads without N wires.

3.3 Working Mode

3.3.1 System Working Mode

Self Consumption Mode

NOTICE

- For solar power, consider self consumption mode in priority: the excess power charges the battery in day time; the battery supplies power to the load when there is no solar power generated at night. This will improve the self consumption rate and saves electricity costs.
- It is suitable for areas with high electricity prices and little or no solar power generation subsidies.

- Day time:
 - When the power generated in the PV system is sufficient, it will supply the loads in priority. The excess power will charge the batteries first, then the remaining power will be sold to the power grid.
 - When the power generated in the PV system is insufficient, the battery will supply the loads in priority. If the battery power is insufficient, the load will be powered by the power grid.
- Night:
 - If the battery power is sufficient, the load will be powered by the battery. If the battery power is not enough, the load will be powered by the power grid.

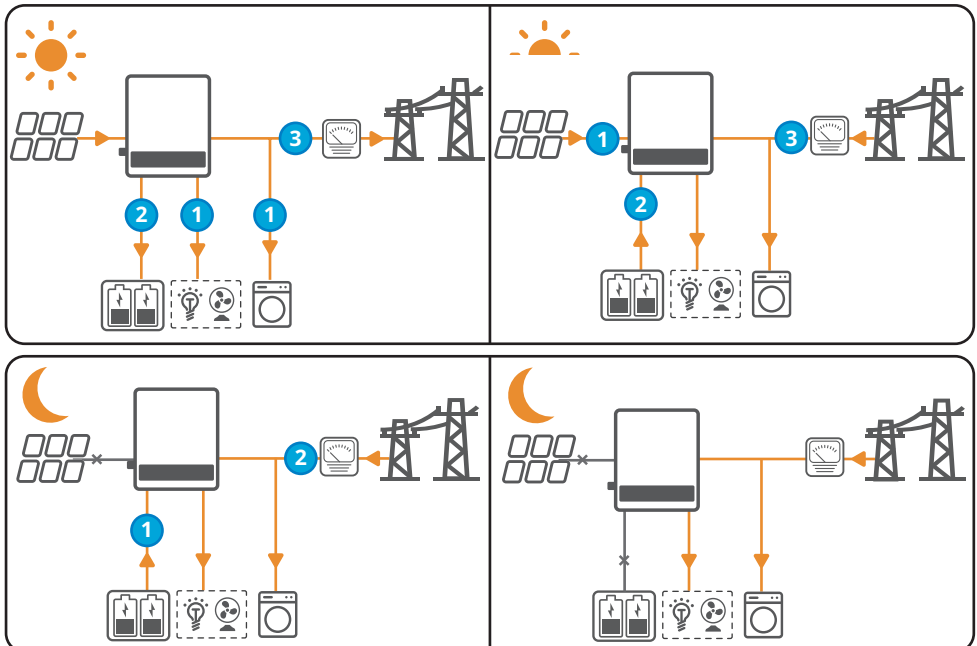

Economic Mode

NOTICE

- Economic mode can only be selected if local laws and regulations are met, such as whether to allow the power grid to charge the battery and whether to allow the battery to be discharged and sold to the power grid. If not, do not select this mode.
- It is recommended to use economic mode in scenarios when the peak-valley electricity price varies a lot.

- Daytime: when the electricity price is at its peak, the battery will power the load first, and the remaining power can be sold to power grid.
- When the electricity price is at its valley, set the time for power grid to charge the battery.

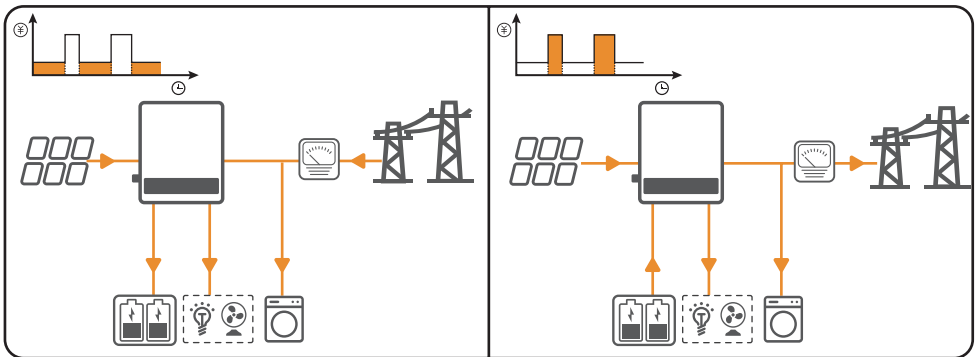

BACK-UP Mode

NOTICE

- The BACK-UP mode can set different battery SOC values during grid connection and off grid. When the power grid loses power, the inverter switches to off grid mode, and the battery can discharge to supply power to the load to ensure that the Back-UP load does not lose power; When the power grid is restored, the inverter switches to grid connected mode. If the battery's SOC is lower than the set SOC, the battery can be charged by power grid.
- The purchase of electricity from the power grid to charge the battery must comply with local laws and regulations.
- Recommended for use in areas with unstable power grids.

- When the SOC of the battery is lower than the set value, using solar power generation and purchasing electricity from the power grid to load and charge the battery.
- When the power grid is cut off, if the PV power generation cannot meet the load usage, the battery discharge will supplement this part of power to ensure that the BACK-UP end load does not cut off.

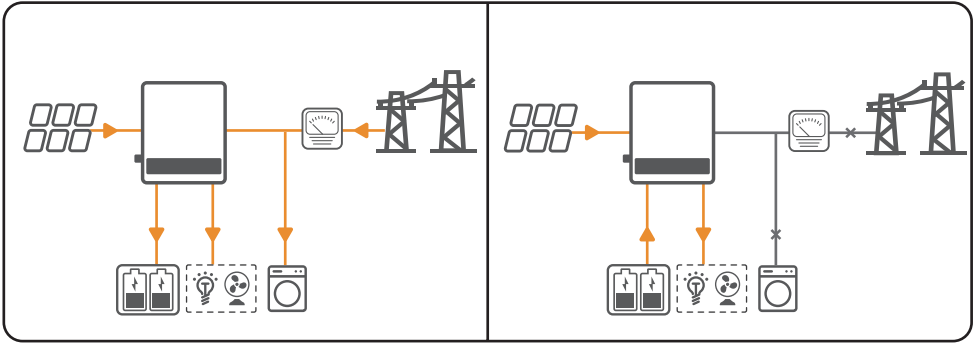

Delayed Charging Mode

NOTICE

- Delayed charging mode can prevent the battery from quickly filling up and wasting energy when the PV energy exceeds the limit power value.
 - It applies to regions with grid connected power output limitations.
-
- Daytime: After solar power generation prioritizes meeting the load usage, when the excess PV power is less than the limit power value, priority will be given to selling the electricity to the power grid; When the excess PV energy exceeds the limit power value, use the power exceeding the limit output power to charge the battery to prevent power waste.
 - Night: If the battery power is sufficient, the load will be powered by the battery. If the battery power is not enough, the load will be powered by the grid.

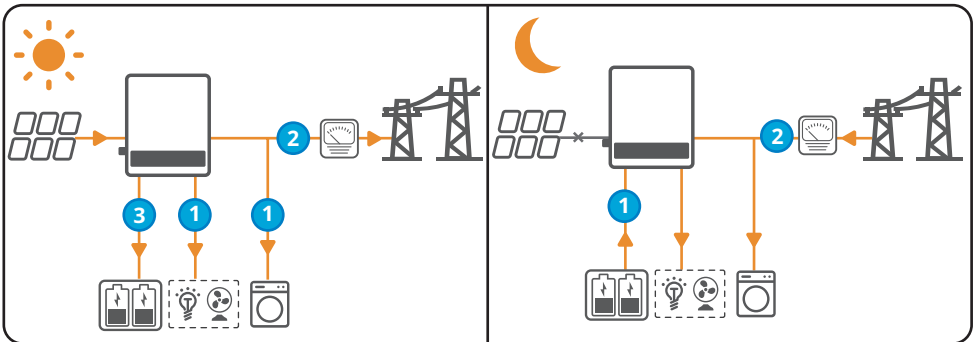

Peak Shaving mode

NOTICE

Peak Shaving mode is mainly applicable to industrial and commercial scenarios. When the total power consumption of the load exceeds the power consumption quota in a short period of time, battery discharge can be used to reduce the power exceeding the quota.

- When the sum of PV power generation and the power purchased from the grid exceeds the power used by the load, the excess power can charge the battery.
- When the power used by the load exceeds the sum of PV power generation and the power purchased from the grid, the battery discharges to supplement the excess power.

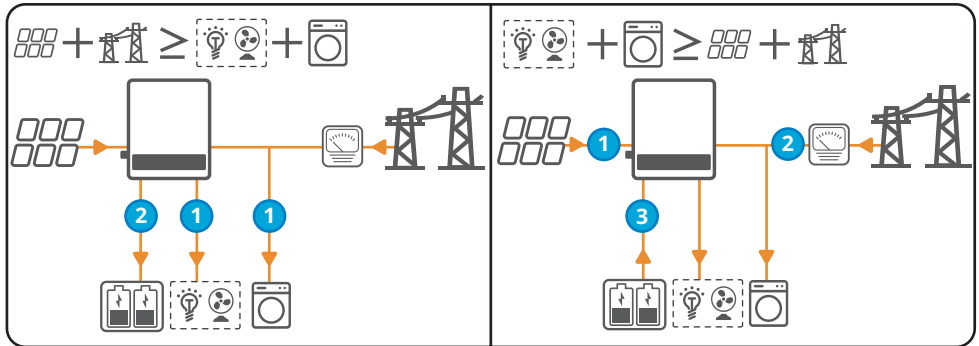

3.3.2 Inverter Operation Mode

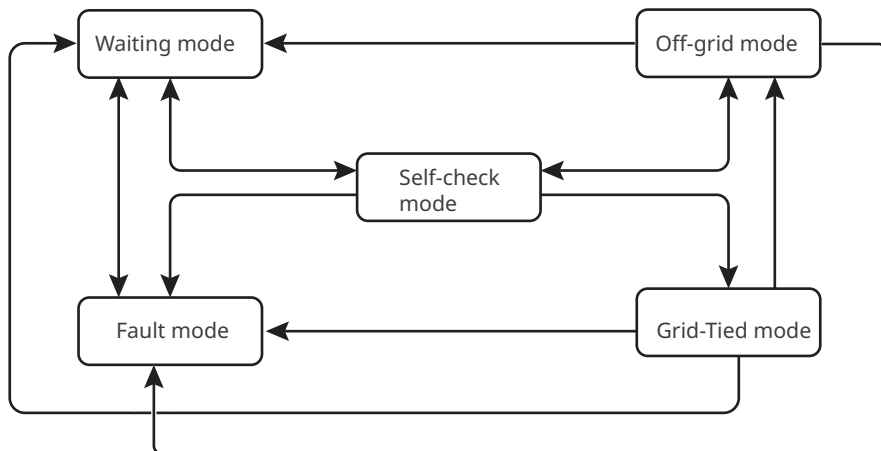

No.	Parts	Description
1	Waiting mode	Waiting stage after the inverter is powered on. <ul style="list-style-type: none"> When the conditions are met, it enters the self-check mode. If there is a fault, the inverter enters the fault mode.
2	Self-check mode	Before the inverter starts up, it continuously performs self-check, initialization, etc. <ul style="list-style-type: none"> When the conditions are met, it enters the grid-tied mode, and the inverter starts on grid connection. If the grid is not detected, it enters the off-grid mode and the inverter runs off-grid; if the inverter has no off-grid function, it enters the wait mode. If the self-check is not passed, it enters the fault mode.
3	Grid-Tied mode	The inverter is grid-tied successfully. <ul style="list-style-type: none"> If the grid is not detected, it enters the off-grid mode. If a fault is detected, it enters the fault mode. If the conditions do not meet grid-tied requirements and the off-grid output function is not turned on, it enters the wait mode.
4	Off-grid mode	When the grid is powered off, the inverter switches to the off-grid mode and continues to supply power to the load via BACK-UP port. <ul style="list-style-type: none"> If a fault is detected, it enters the fault mode. If the conditions do not meet grid-tied requirements and the off-grid output function is not turned on, it enters the wait mode. If the conditions meet grid-tied requirements and the off-grid output function is turned on, it enters the self-check mode.
5	Fault mode	If a fault is detected, the inverter enters the fault mode. When the fault is cleared, it enters the wait mode.

3.4 Features

Power derating

For a safe operation, the inverter will automatically reduce the output power when the operating environment is not ideal.

The following are the factors that may occur power derating. Please try to avoid them during usage.

- Unfavorable environmental conditions, e.g., direct sunlight, high temperature, etc.
- Inverter's output power percentage has been set.
- Over-frequency derating.
- Higher input voltage value.
- Higher input current value.

AFCI

Reasons to occur electric arcs.

- Damaged connectors in the PV or battery system.
- Wrong connected or broken cables.
- Aging connectors and cables.

Methods to detect electric arcs

- The inverter has an integrated AFCI function.
- When the inverter detects an electric arc, users can find the time of the fault and the detailed phenomenon through the app.
- The alarm can be cleared automatically if the inverter triggers a fault for less than 5 times within 24 hours. The inverter will shutdown for protection after the 5th electric arc fault. The inverter cannot work normally until the fault is solved. Please refer to the SolarGo App User Manual for detailed operations.

RSD

A signal transmitter is integrated into the inverter to communicate with the external RSD. In the event of an emergency, the external switch will be enabled to stop the receiver, then disconnect the PV modules.

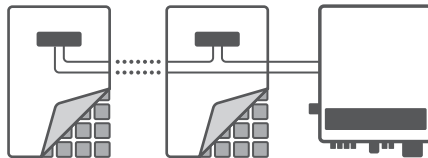

Earth Fault Alarm

Reserved port for earth fault alarm.

Once an earth fault occurs, the LED indicator will light up. And the system will email the fault information to the customer. Install the inverter in a high traffic area where the indicators would be noticed.

Load Control

The inverter reserves a dry contact controlling port, which supports connecting additional contactors to enable/disable the loads, such as household loads, heat pumps, etc.

The load control methods are as follows:

- Time control: set the time to enable/disable the loads, and the loads will be turned on or off automatically within the setting time period.
- Switch control: when the control mode is ON, the loads will be enabled; when it is OFF, the loads will be disabled.
- BACK-UP load control: the inverter has an integrated relay controlling port, which can control the loads off or on. In off-grid mode, the loads connected to the relay port can be turned off if the overload at BACK-UP is detected or the battery SOC value is lower than the battery off-grid protection setting.

For more detailed instructions, please refer to the SolarGo User Manual.

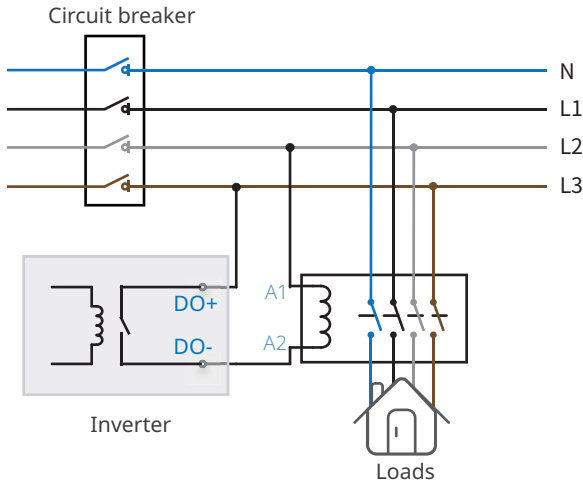

SolarGo
User Manual

3.5 Appearance

3.5.1 Parts

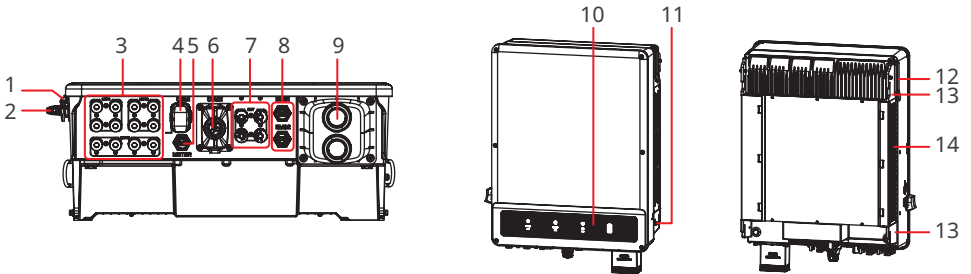







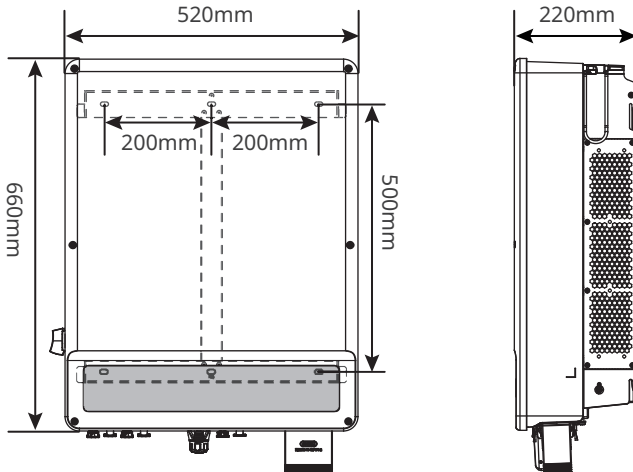









- | | | |
|---------------------------------------|-----------------------------|---|
| 1. DC switch lock hole ^[1] | 2. DC switch | 3. PV input terminal (PV+/-) |
| 4. Communication module port (COM) | 5. METER communication port | 6. Communication port (COM2) |
| 7. Battery input terminal (BAT+/-) | 8. BMS communication port | 9. AC output terminal (On-Grid and Back-Up) |
| 10. Indicators | 11. PE terminal | 12. Handle |
| 13. Mounting plate | 14. Heat Sink | |

[1]: Only for Australia.

3.5.2 Dimension



3.5.3 Indicators

Indicator	Status	Description
		The inverter is power on and in the standby mode.
		The inverter is starting up and in the self-check mode.
		The inverter is in normal operation under grid-tied or off-grid modes.
		BACK-UP output overload.
		A fault has occurred.
		The inverter is powered off.
		The grid is abnormal and the inverter is in off-grid mode.
		The grid is normal and the inverter is in grid-tied mode.
		BACK-UP is off.
		The monitoring module of the inverter is resetting.
		The inverter fails to connect with the communication Termination.
		Communication fault between the communication Termination and Server.
		The monitoring of the inverter operates well.
		The monitoring module of the inverter has not been started yet.

3.5.4 Nameplate

The nameplate is for reference only.

GOODWE	
Product: Hybrid Inverter	
Model: ***	
PV Input	UDC max: ***Vd.c.
	UMPP: ***Vd.c.
	Idc,max: ***Ad.c.
	ISC PV: ***Ad.c.
Battery	Ubatt: ***Vd.c.,Li-Ion
	Ibatt,max(C/D): ***Ad.c
On-grid	UAC: ***Va.c.
	fAC: ***Hz
	PAC: ***kW
	IAC,max(to grid): ***Aa.c.
	Sr(to grid): ***kVA
	Smax(to grid): ***kVA
	IAC(from grid): ***Aa.c.
	Sr(from grid): ***kVA
Smax(from grid): ***kVA	
Back-up	UAC,r: ***Va.c.
	fAC,r: ***Hz
	IAC,max: ***Aa.c.
	Sr: ***kVA
	Smax: ***kVA
P.F.: -1,0.8cap...0.8ind, TOperating: -35~60°C Non-isolated, IP66, Protective Class I, OVC DCII/ACIII	
S/N:	
Good We Technologies Co., Ltd. E-mail: service@goodwe.com No.90 Ziji n Rd., New District, Suzhou, 215011, China S/N	

GW trademark, product type, and product model

Technical parameters

Safety symbols and certification marks

Contact information and serial number

4 Check and Storage

4.1 Check Before Receiving

Check the following items before receiving the product.

1. Check the outer packing box for damage, such as holes, cracks, deformation, and other signs of equipment damage. Do not unpack the package and contact the supplier as soon as possible if any damage is found.
2. Check the inverter model. If the inverter model is not what you requested, do not unpack the product and contact the supplier.
3. Check the deliverables for correct model, complete contents, and intact appearance. Contact the supplier as soon as possible if any damage is found.

4.2 Deliverables



WARNING

Connect the DC cables with the included terminals. The manufacturer shall not be liable for the damage if other terminals are used.

NOTICE

The number of pin terminals, PV connectors, and battery connectors are various depending on different inverters. The actual accessories may differ.

PV connector: GW15K/20K-ET: 4 x PV+/PV-; GW25K/29.9K/30K-ET: 6 x PV+/PV-.

Battery connector: GW15K/20K-ET: 1 x BAT+/BAT-; GW25K/29.9K/30K-ET: 2 x BAT+/BAT-.

BMS communication cable: GW15K/20K-ET: 1; GW25K/29.9K/30K-ET: 2; Meter communication cable GW15K/20K-ET: 1; GW25K/29.9K/30K-ET: 1.

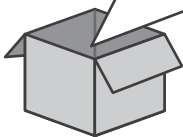
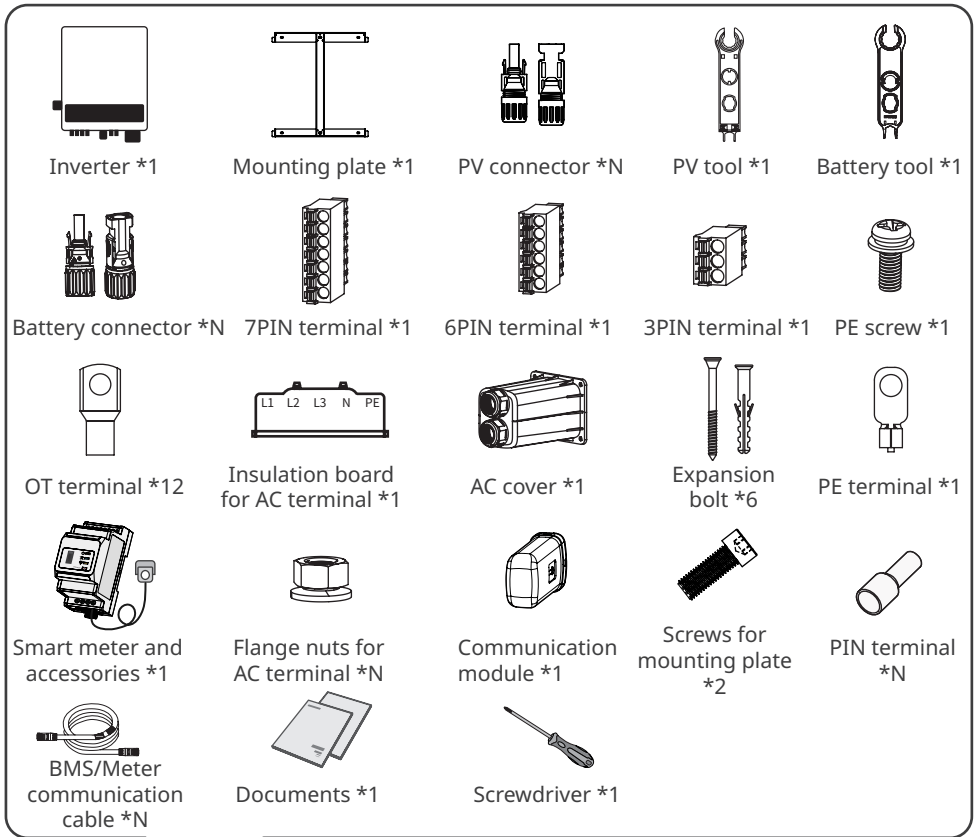

4.3 Storage

If the equipment is not to be installed or used immediately, please ensure that the storage environment meets the following requirements:

1. Do not unpack the outer package or throw the desiccant away.
2. Store the equipment in a clean place. Make sure the temperature and humidity are appropriate and no condensation.
3. The height and direction of the stacking inverters should follow the instructions on the packing box.
4. The inverters must be stacked with caution to prevent them from falling.
5. If the inverter has been long term stored, it should be checked by professionals before being put into use.

5 Installation

5.1 Installation Requirements

Installation Environment Requirements

1. Do not install the equipment in a place near flammable, explosive, or corrosive materials.
2. Do not install the equipment in a place that is easy to touch, especially within children's reach. High temperature exists when the equipment is working. Do not touch the surface to avoid burning.
3. Avoid the water pipes and cables buried in the wall when drilling holes.
4. Install the equipment in a sheltered place to avoid direct sunlight, rain, and snow. Build a sunshade if it is needed.
5. The place to install the equipment shall be well-ventilated for heat radiation and large enough for operations.
6. The equipment with a high ingress protection rating can be installed indoors or outdoors. The temperature and humidity at the installation site should be within the appropriate range.
7. Install the equipment at a height that is convenient for operation and maintenance, electrical connections, and checking indicators and labels.
8. The altitude to install the inverter shall be lower than the maximum working altitude 4000m.
9. Install the equipment away from electromagnetic interference. If there are radio stations or wireless communication equipment below 30 MHz near the installation location, please install the equipment as follows:
 - Add a multi-turn winding ferrite core at the DC input line or AC output line of the inverter, or add a low-pass EMI filter.
 - The distance between the inverter and the wireless EMI equipment is more than 30m.

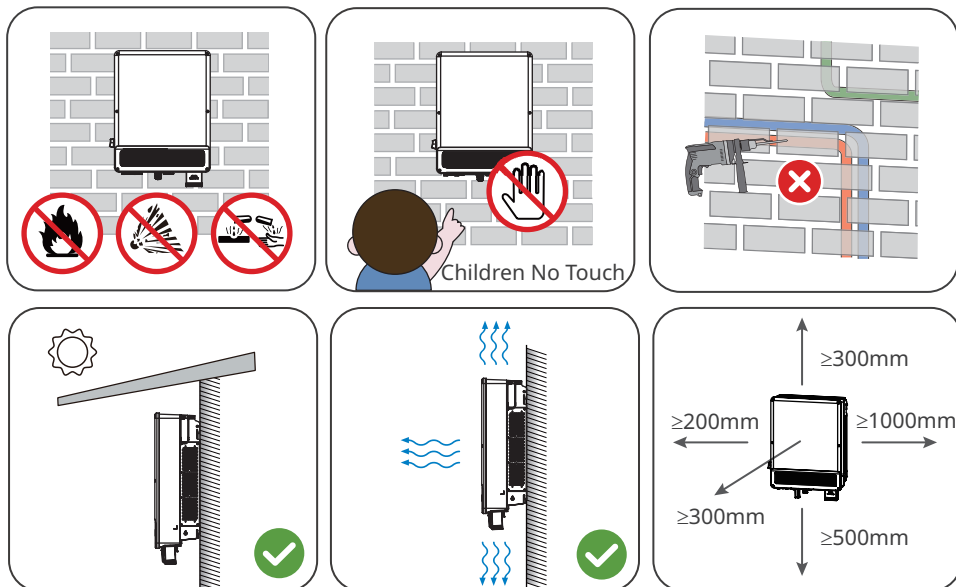

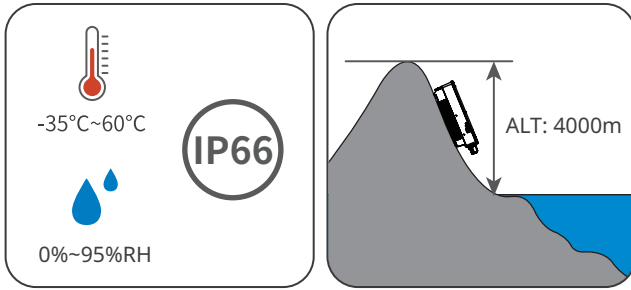

Mounting Support Requirements

- The mounting support shall be nonflammable and fireproof.
- Install the equipment on a surface that is solid enough to bear the inverter weight.
- Do not install the product on the support with poor sound insulation to avoid the noise generated by the working product, which may annoy the residents nearby.

Installation Angle Requirements

- Install the inverter vertically or at a maximum back tilt of 15 degrees.
- Do not install the inverter upside down, forward tilt, backward tilt, or horizontally.

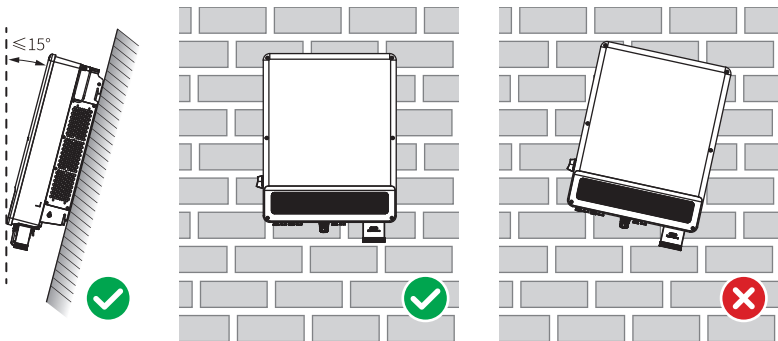

Installation Tool Requirements

The following tools are recommended when installing the equipment. Use other auxiliary tools on site if necessary.

				
Goggles	Safety shoes	Safety gloves	Dust mask	RJ45 crimping tool
				
Diagonal pliers	Wire stripper	Hammer drill	Heat gun	Vacuum cleaner
				
Marker	Level	Heat shrink tube	Rubber hammer	Torque wrench
				
Multimeter	Cable tie			

5.2 Inverter Installation

5.2.1 Moving the Inverter

CAUTION

- Operations such as transportation, turnover, installation and so on must meet the requirements of the laws and regulations of the country or region where it is located.
- Move the inverter to the site before installation. Follow the instructions below to avoid personal injury or equipment damage.
 1. Consider the weight of the equipment before moving it. Assign enough personnel to move the equipment to avoid personal injury.
 2. Wear safety gloves to avoid personal injury.
 3. Keep balance to avoid falling down when moving the equipment.

5.2.2 Installing the Inverter

NOTICE

- Avoid the water pipes and cables buried in the wall when drilling holes.
- Wear goggles and a dust mask to prevent the dust from being inhaled or contacting eyes when drilling holes.
- Make sure the inverter is firmly installed in case of falling down.
- The DC switch lock of appropriate size should be prepared by customers. The diameter of the lock hole is 5mm. The lock might not be able to install if the size is inappropriate.

Step 1: Put the plate on the wall horizontally and mark positions for drilling holes.

Step 2: Drill holes to a depth of 80mm using the hammer drill. The diameter of the drill bit should be 8mm.

Step 3: Use the expansion bolts to fix the inverter on the wall.

Step 4: (Optional) Secure the DC switch with the DC switch lock, ensuring that the DC switch is "OFF" during installation.

Step 5: Install the inverter on the mounting plate. For models with handles, please lift the inverter using the handles. For models without handles, please lift the inverter directly.

Step 6: Tighten the nuts to secure the mounting plate and the inverter.

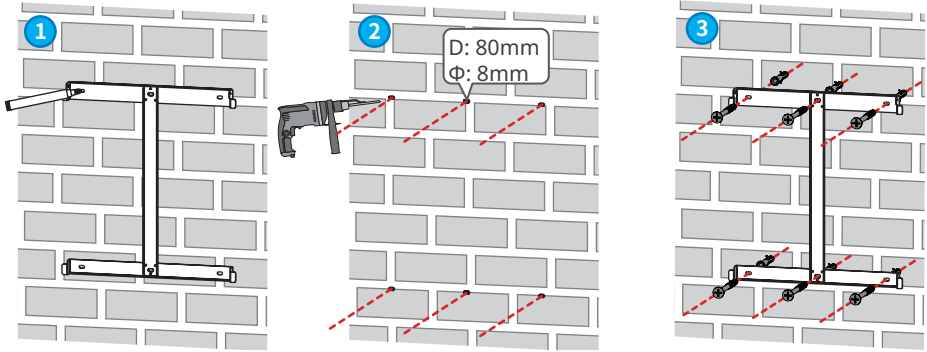

5 With handles

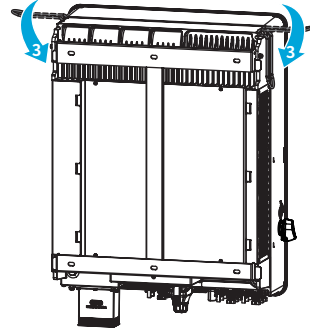
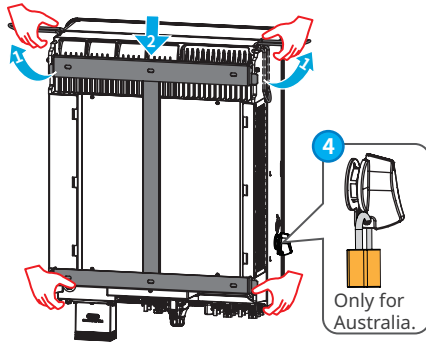

5 Without handles

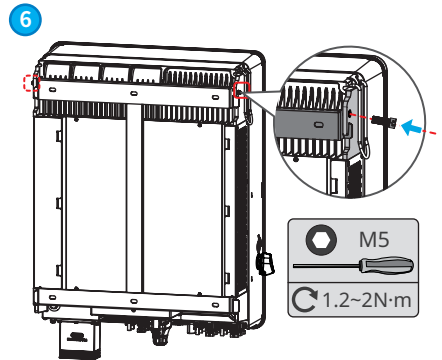
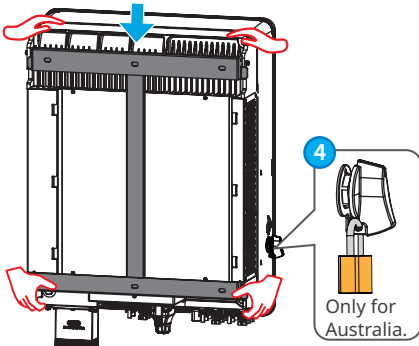

6 Electrical Connection

6.1 System Wiring Diagram

NOTICE

- N and PE wiring via ON-GRID and BACK-UP ports of the inverter are different based on the regulation requirements of different regions. Refer to the specific requirements of local regulations.
- There are built-in relays inside of the inverter’s ON-GRID and BACK-UP AC ports. When the inverter is in the off-grid mode, the built-in ON-GRID relay is open; while when the inverter is in grid-tied mode, it is closed.
- When the inverter is powered on, the BACK-UP AC port is charged. Power off the inverter first if maintenance is required for the loads connected with BACK-UP ports. Otherwise, it may cause electric shock.

N and PE cables are connected together in the Main Panel for wiring.

NOTICE

- To maintain neutral integrity, the neutral cable of ON-GRID side and BACK-UP side must be connected together, otherwise BACK-UP function will not work.
- The following diagram is applicable to areas in Australia, New Zealand, etc.

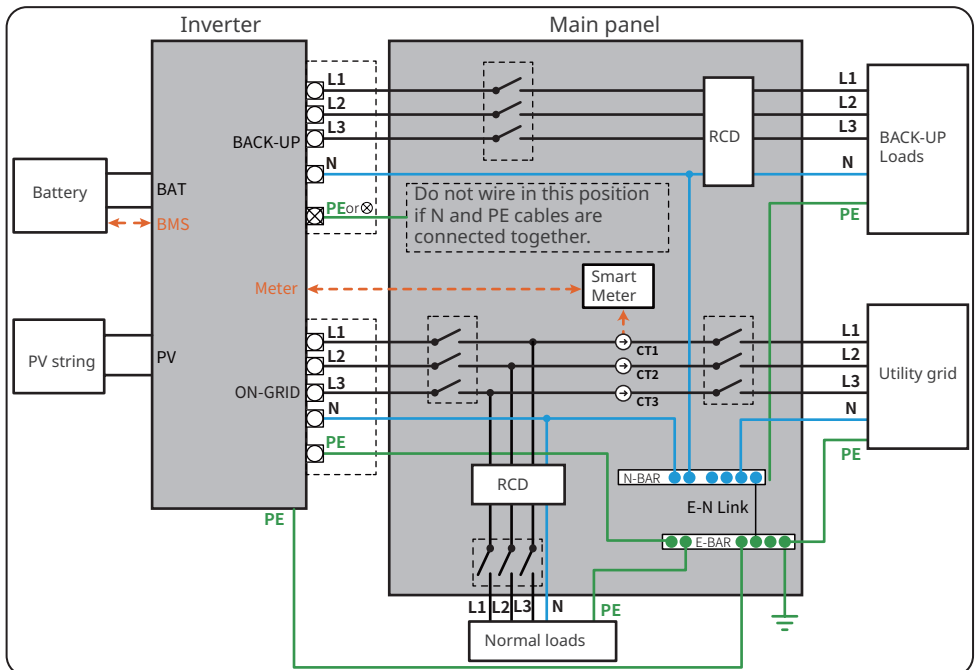

N and PE cables are separately wired in the Main Panel.

NOTICE

- Ensure that the grounding of BACK-UP is correctly and tightened. Otherwise, the BACK-UP function may be abnormal in case of grid failure.
- The following diagram is applicable to areas except Australia, New Zealand.

- In Germany, the internal relay will automatically connect the N wire and PE cable in back-up mode within 100ms and automatically disconnect in on-grid mode.
- In areas other than Germany, the internal relay is disconnected by default in either mode.

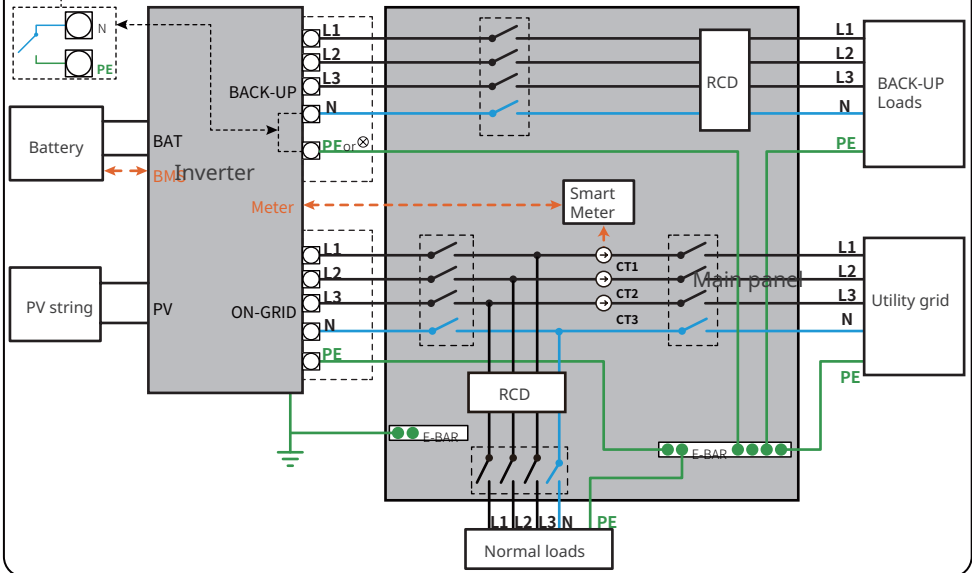

6.2 Safety Precaution

DANGER

- Perform electrical connections in compliance with local laws and regulations. Including operations, cables, and component specifications.
- Disconnect the DC switch and the AC output switch of the inverter to power off the inverter before any electrical connections. Do not work with power on. Otherwise, an electric shock may occur.
- Tie the same type cables together, and place them separately from cables of different types. Do not place the cables entangled or crossed.
- If the cable bears too much tension, the connection may be poor. Reserve a certain length of the cable before connecting it to the inverter cable port.
- When crimping the terminals, ensure that the conductor part of the cable is in full contact with the terminals. Do not crimp the cable jacket with the terminal. Otherwise the inverter may not operate, or its terminal block getting damaged due to heating and other phenomenon because of unreliable connection after operation.

NOTICE

- Wear personal protective equipment like safety shoes, safety gloves, and insulating gloves during electrical connections.
- All electrical connections should be performed by qualified professionals.
- Cable colors in this document are for reference only. The cable specifications shall meet local laws and regulations.

6.3 Connecting the PE cable

WARNING

- The PE cable connected to the enclosure of the inverter cannot replace the PE cable connected to the AC output port. Make sure that both of the two PE cables are securely connected.
- Make sure that all the grounding points on the enclosures are equipotentially connected when there are multiple inverters.
- To improve the corrosion resistance of the terminal, you are recommended to apply silica gel or paint on the ground terminal after installing the PE cable.
- The PE cable should be prepared by the customer. Recommended specifications:
 - Type: single-core outdoor copper cable
 - Conductor cross-sectional area: 4-6mm²

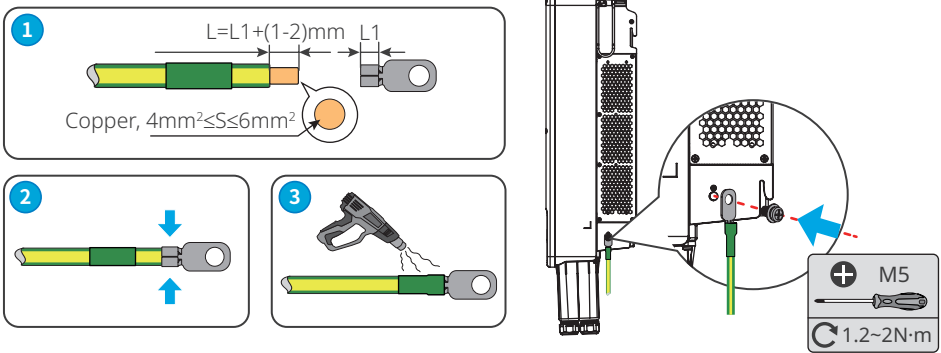

6.4 Connecting the DC Input Cable(PV)

DANGER

- Do not connect one PV string to more than one inverter at the same time. Otherwise, it may cause damage to the inverter.
- Confirm the following information before connecting the PV string to the inverter. Otherwise, the inverter may be damaged permanently or even cause fire and cause personal and property losses.
 - Make sure that the max short circuit current and the max input voltage per MPPT are within the permissible range.
 - Make sure that the positive pole of the PV string connects to the PV+ of the inverter. And the negative pole of the PV string connects to the PV- of the inverter.

WARNING

The PV strings cannot be grounded. Ensure the minimum insulation resistance of the PV string to the ground meets the minimum insulation resistance requirements before connecting the PV string to the inverter ($R = \text{maximum input voltage} / 30\text{mA}$).

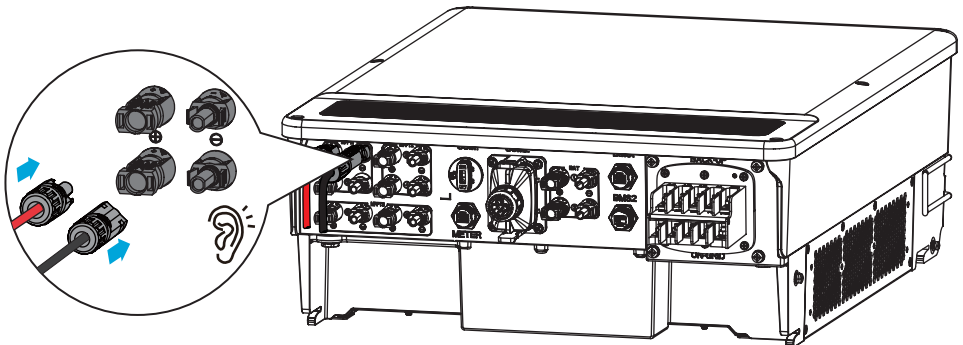

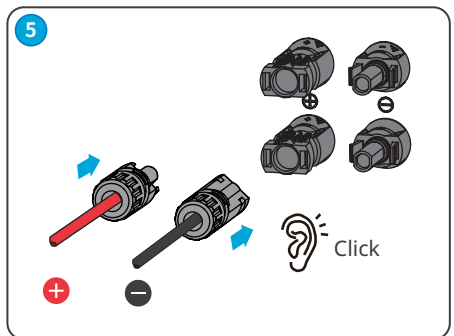
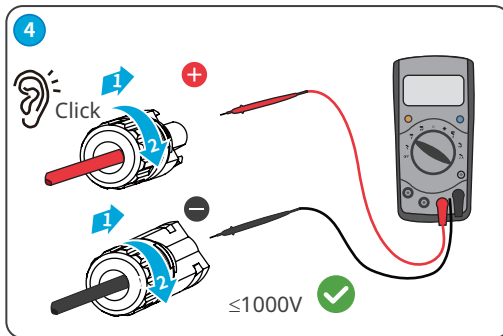
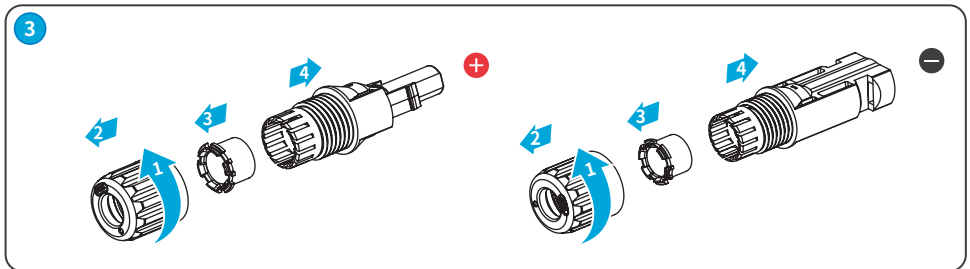
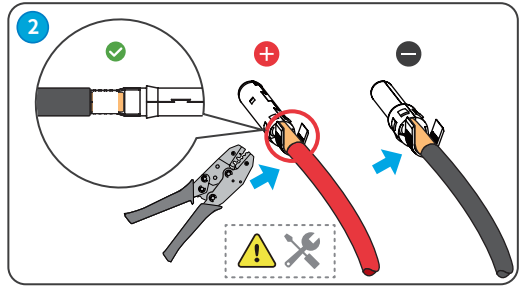
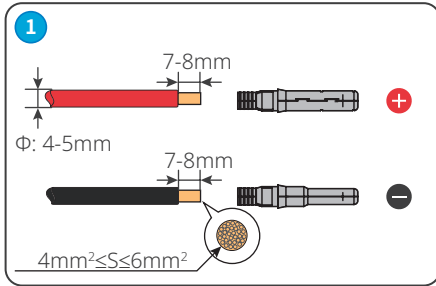

6.5 Connecting the Battery Cable

DANGER

- The battery used with the inverter shall be approved by the inverter manufacturer. The approved battery list can be obtained through the official website.
- A short circuit in the battery may cause personal injury. The instantaneous high current caused by a short circuit can release a large amount of energy and may cause a fire.
- Before connecting the battery cable, ensure the inverter and the battery, and downstream&upstream switches, are all disconnected.
- It is forbidden to connect and disconnect the battery cables when the inverter is running. Otherwise it may cause electric shock.
- Do not connect one battery pack to more than one inverter at the same time. Otherwise, it may cause damage to the inverter.
- It is forbidden to connect loads between the inverter and batteries.
- When connecting battery cables, use insulated tools to prevent accidental electric shock or short circuit to the batteries.
- Ensure that the open circuit voltage of the battery is within the permissible range of the inverter.
- Install a DC breaker between the inverter and the battery.

WARNING

- Connect the battery cables to the corresponding terminals such BAT+, BAT- and grounding ports correctly. Otherwise it will cause damage to the inverter.
- Ensure that the whole cable cores are inserted into the terminal holes. No part of the cable core can be exposed.
- Ensure that the cables are connected securely. Otherwise it will cause damage to the inverter due to overheat during its operation.

NOTICE

- Delayed charge cannot be set to 100% if the PV is oversizing.
- Connecting the BMS communication cable for battery communication when connecting the inverter to the battery. For more detailed instructions, refer to [6.7.3 Connecting the BMS or Meter Communication Cable](#).
- The batteries and inverters should be connected in different ways when the inverter models differ or the number of batteries differ, as explained below:

GW15K-ET or GW20K-ET can be connected to only one battery system. The battery cable must be connected to BAT1, as shown below.

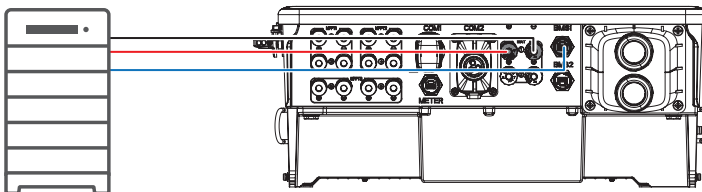

GW25K-ET, GW29.9K-ET, and GW30K-ET can be connected to one or two battery systems, as shown below.

Single battery system connected to BAT1 of the inverter.

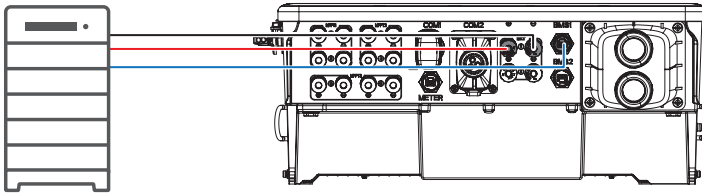

Single battery system connected to BAT2 of the inverter.

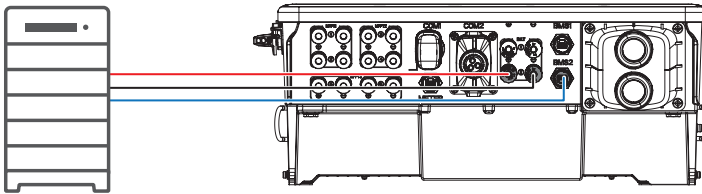

Single battery system connected to both BAT1 and BAT2 of the inverter.

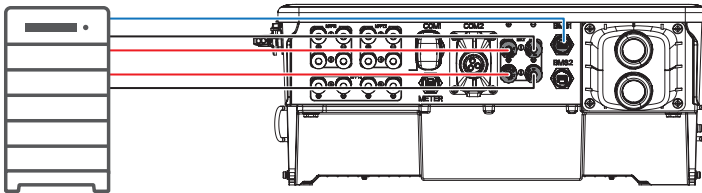

Battery systems connected to BAT1 and BAT2 of the inverter respectively.

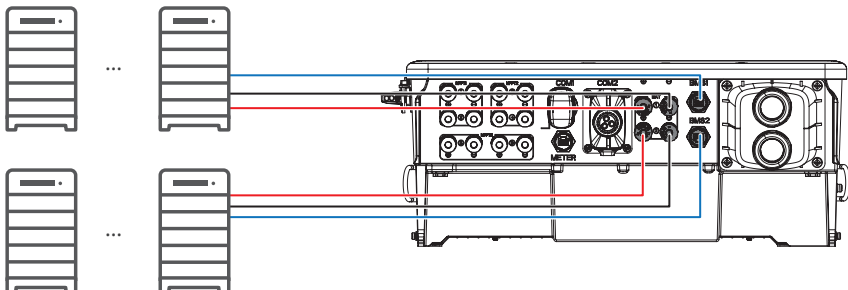

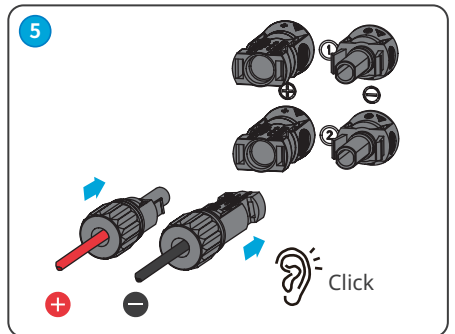
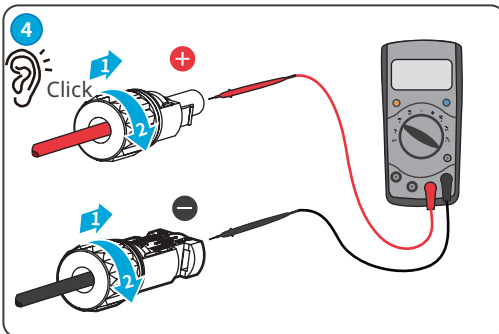
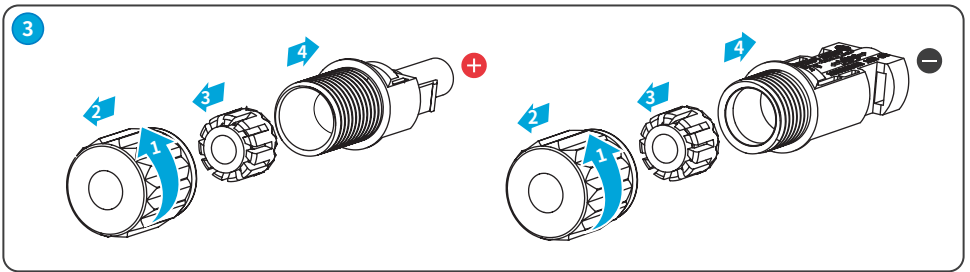
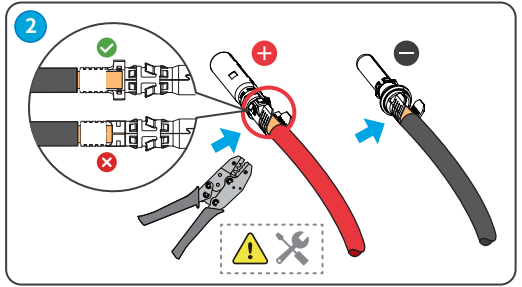
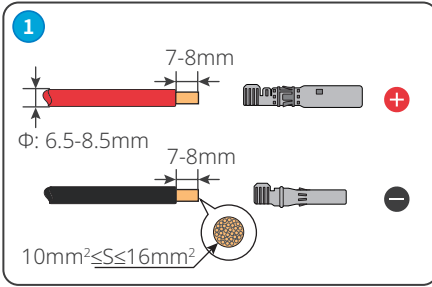
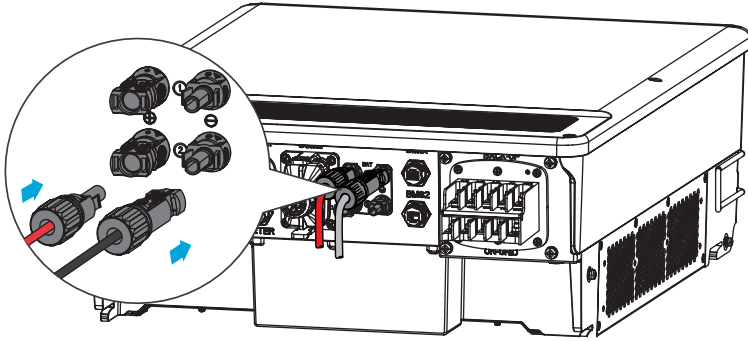

6.6 Connecting the AC Cable

WARNING

Do not connect loads between the inverter and the AC switch directly connected to the inverter.

The residual current monitoring unit (RCMU) is integrated into the inverter to avoid the residual current exceeds the limit.

The type A RCD can be connected to the inverter for protection according to the local laws and regulations. Recommended specifications: ON-GRID RCD: 300mA; BACK-UP RCD: 30mA.

NOTICE

- Install one AC output circuit breaker for each inverter. Multiple inverters cannot share one AC circuit breaker.
- An AC circuit breaker shall be installed on the AC side to make sure that the inverter can safely disconnect the grid when an exception happens. Select the appropriate AC circuit breaker in compliance with local laws and regulations.

WARNING

- Connect the AC cables to the corresponding terminals such as "L1", "L2", "L3", "N", and PE correctly. Otherwise it will cause damage to the inverter.
- Ensure that the whole cable cores are inserted into the terminal holes. No part of the cable core can be exposed.
- Ensure that the insulation board is inserted into the AC terminal tightly.
- Ensure that the cables are connected securely. Otherwise it will cause damage to the inverter due to overheat during its operation.

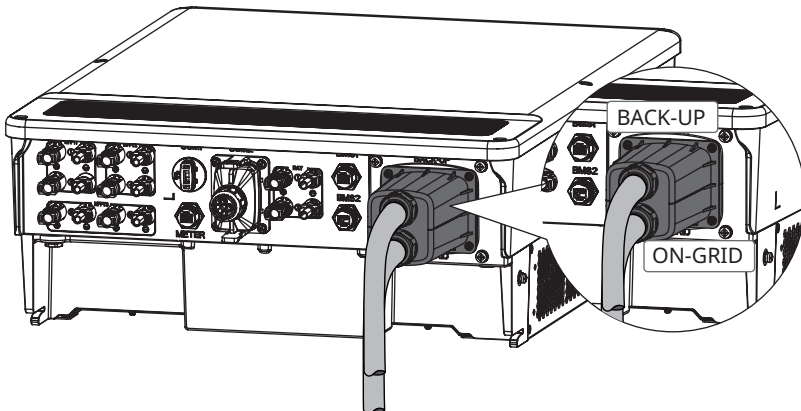

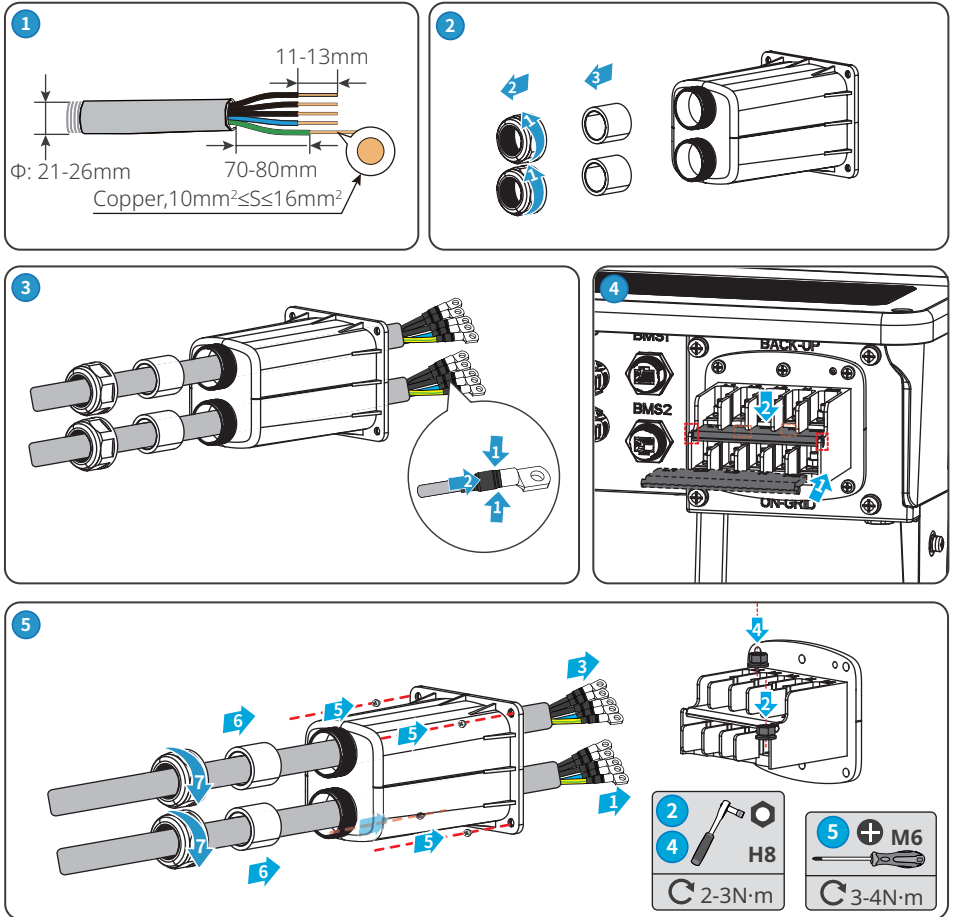

6.7 Communication Connection

NOTICE

- Make sure that the communication device is connected to the right COM port. Route the communication cable far away from any interference source or power cable to prevent the signal from being influenced.
- The remote shutdown function and DRED/RCR function is off by default. Please go to the SolarGo app to enable the function if you need to use it. Please refer to the SolarGo User Manual for detailed operations.

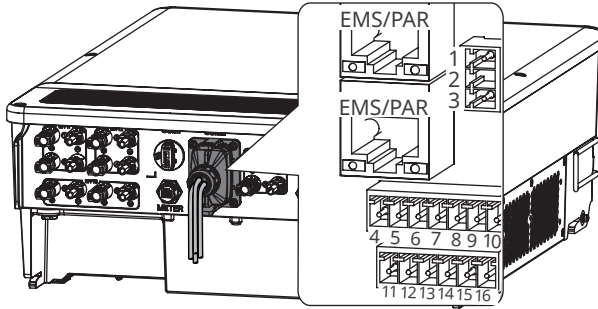

No.	Port Definition	Function	Description
1	DO1+	Dry contact	The inverter reserves a dry contact controlling port, which supports connecting additional contactors to enable/disable the load. For high voltage AC230V. PIN2 is reserved for safety regulations.
2	NC	Reserved PIN	
3	DO1-	Dry contact	
4	GND	Power supply	Supplies power for external devices.
5	12V_S		
6	RSD_12V	Controls the RSD modules externally.	Optional. Connects to RSD_12V and 12V_S to control the RSD module rapidly.
7	GND	Remote shutdown	Controls the equipment on/off remotely.
8	Remote shutdown		
9	DO2+	Dry contact	The inverter reserves a dry contact controlling port, which supports connecting additional contactors to enable/disable the load.
10	DO2-		
11	COM/DRM0 or REF_1	DRED or RCR	<ul style="list-style-type: none"> DRED (Demand Response Enabling Device): the inverter satisfies the Australian DERD certification and offers DRED signal controlling ports. RCR (Ripple Control Receiver): In Germany and some other European regions, grid companies use Ripple Control Receiver to convert grid dispatching signals into dry contact mode for transferring. And the power station receives grid dispatching signals through dry contact communication mode.
12	REFGEN or REF_2		
13	DRM4/8 or DI_4		
14	DRM3/7 or DI_3		
15	DRM2/6 or DI_2		
16	DRM1/5 or DI_1		
17	EMS/PAR	EMS communication or parallel connection port	<ul style="list-style-type: none"> EMS communication port: connects with the third party device. PAR communication port: reserved, serves as the communication port for the inverter parallelizing.

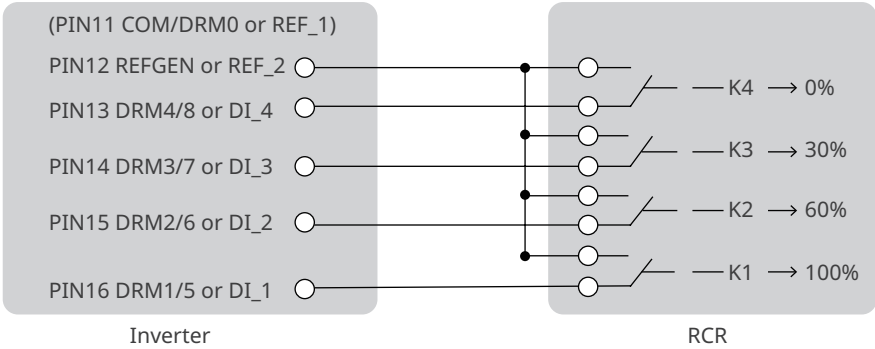

6.7.1 Connecting the Communication Cable (Terminal Block)

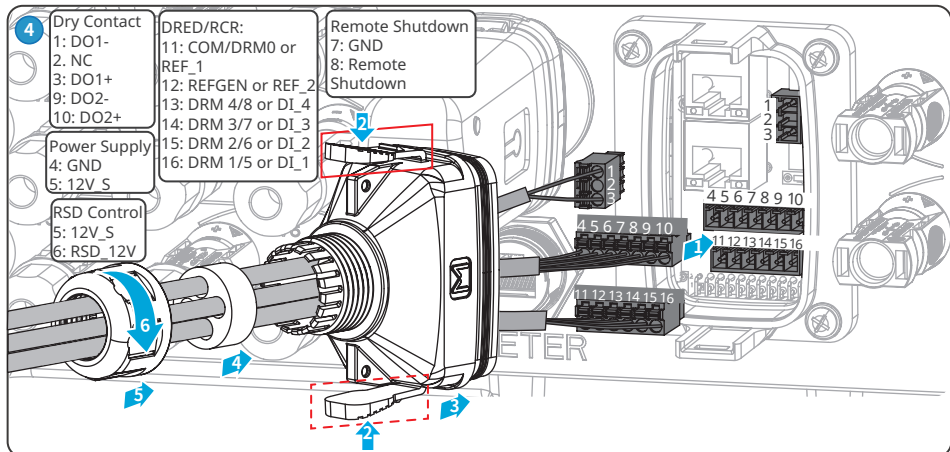
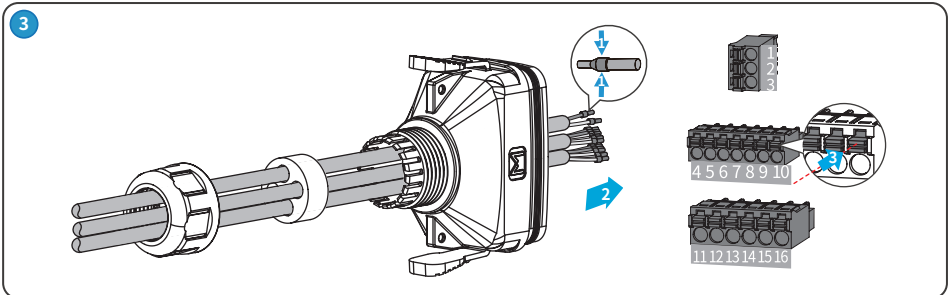
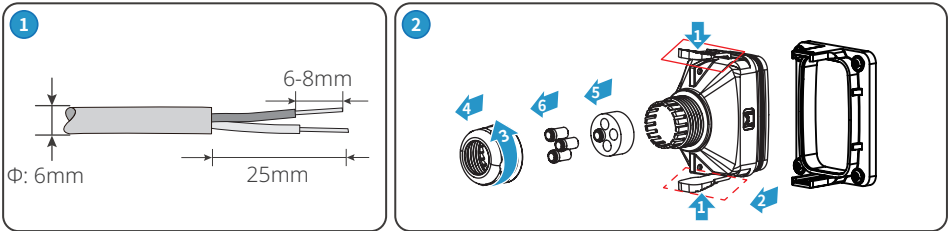

6.7.2 Connecting the Communication Cable (RJ45 Connector)

NOTICE

RJ45 connector with the following definition can be connected:

PIN	Color	EMS/PAR
1	Orange and White	485A3
2	Orange	485B3
3	Green and White	NC
4	Blue	GND
5	Blue and White	CAN_L
6	Green	CAN_H
7	Brown and White	SYN_BUS1
8	Brown	SYN_BUS2

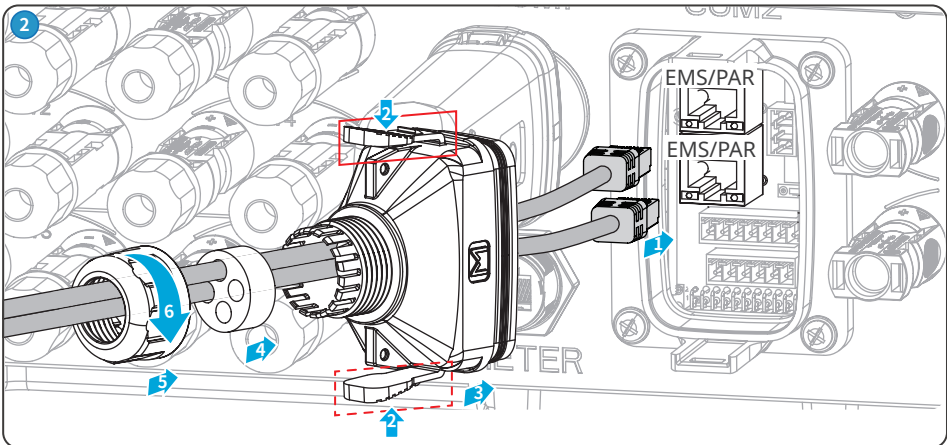
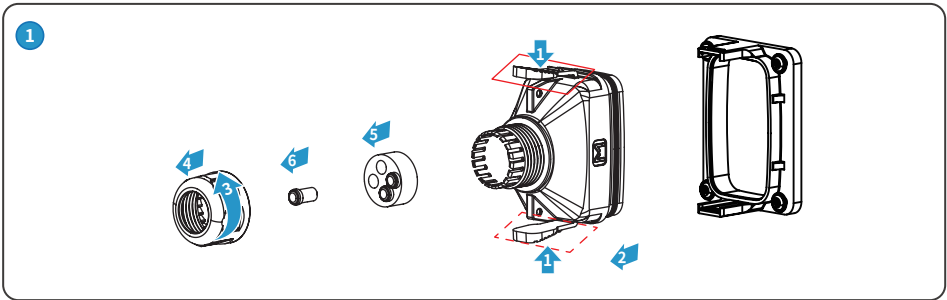
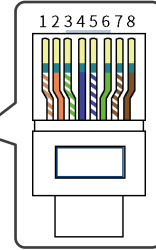

6.7.3 Connecting the BMS or Meter Communication Cable

 **WARNING**

- For GW15K-ET and GW20K-ET, please connect the cable to BMS1 port to realize BMS communication. Otherwise, BMS communication may fail.
- For GW25K-ET, GW29.9K-ET, and GW30K-ET, please connect the cable to BMS1 port to realize BMS communication when single battery system is connected. Otherwise, BMS communication may fail. For more details, refer to [6.5 Connecting the Battery Cable](#).

NOTICE

- The smart meter and CT have been preset parameters before delivered with the inverter. Do not modify the relevant parameters.
- The BMS communication cable and meter communication cable are delivered with the inverter, with default length of 5m and 10m respectively.
- Each inverter needs to be connected to one smart meter independently. Do not connect one smart meter to multiple inverters. Contact the manufacturer or supplier to purchase additional smart meter(s) if you need.
- Ensure that CT connects with the corresponding phase line: CT1 is connected to L1; CT2 is connected to L2; and CT3 is connected to L3. And ensure that the CT is connected in the right direction. Please refer to the smart meter user manual for detailed operations.
- Use the included BMS communication cable to realize communication between the inverter and the battery. Otherwise, the communication may fail. Make the RJ45 connector as following if you need to prepare the cable by yourself:

PIN	Color	Smart Meter	BMS1	BMS2
1	Orange and White	NC	485_A2	485_A4
2	Orange	NC	485_B2	485_B4
3	Green and White	NC	NC	NC
4	Blue	NC	CANH1	CANH2
5	Blue and White	NC	CANL1	CANL2
6	Green	NC	NC	NC
7	Brown and White	485_B1	NC	NC
8	Brown	485_A1	NC	NC

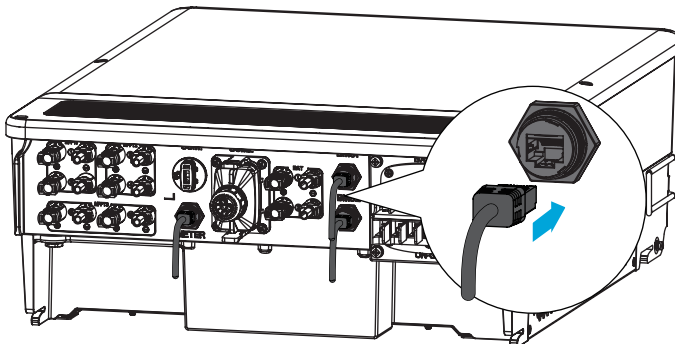
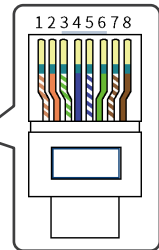

Power Limit Network

NOTICE

Power limit can be realized when the inverter is installed with the Meter. Testing to AS/NZS 4777.2:2020 for multiple inverter combinations has not been conducted. The specific networking schemes are:

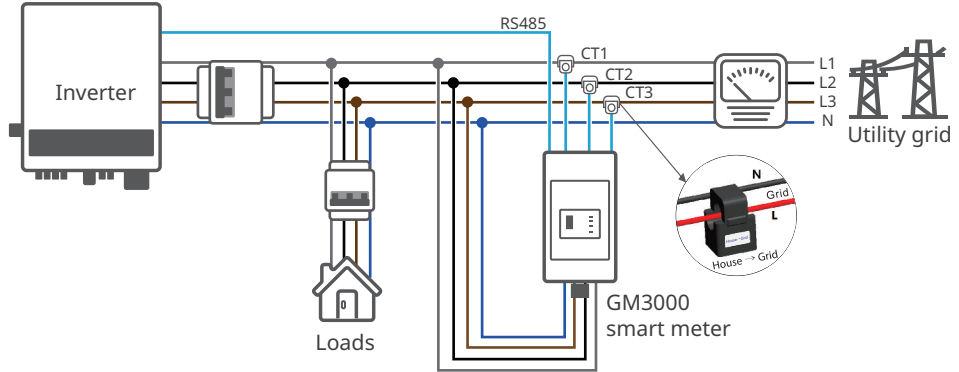

6.7.4 Installing the Communication Module (Optional)

NOTICE

- Plug a communication module into the inverter to establish a connection between the inverter and the smartphone or web pages. The communication module can be a Bluetooth module, WiFi module, LAN module, or 4G module. Set inverter parameters, check running information and fault information, and observe system status in time via the smartphone or web pages.
- Refer to the delivered communication module user manual to get more introduction to the module. For more detailed information, visit www.goodwe.com.
- Bluetooth kit, WiFi kit module: Standard. LAN kit, 4G kit module: optional.

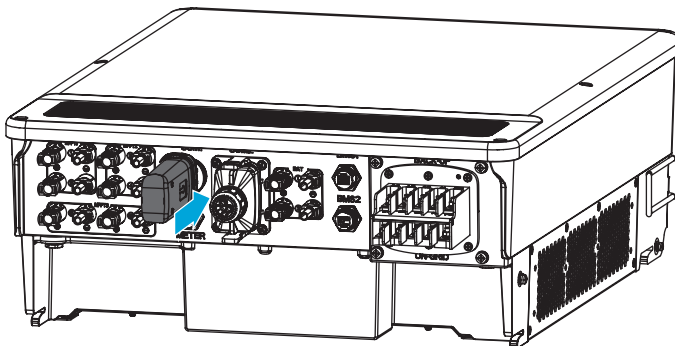

7 Equipment Commissioning

7.1 Check Before Power ON

No.	Check Item
1	The product is firmly installed at a clean place that is well-ventilated and easy-to operate.
2	The PE, DC input, AC output, and communication cables are connected correctly and securely.
3	Cable ties are intact, routed properly and evenly.
4	Unused cable holes are fitted using the waterproof nuts.
5	The electrical conduit holes are sealed.
6	The voltage and frequency at the connection point meet the inverter grid connection requirements.

7.2 Power On

Step 1: Turn on the AC breaker on the ON-GRID side of the inverter.

















Step 2: Turn on the AC breaker on the BACK-UP side of the inverter.

Step 3: Turn on the battery breaker between the inverter and the battery.

Step 4: Turn on the DC switch of the inverter.

8 System Commissioning

8.1 Indicators and Buttons

Indicator	Status	Description
		The inverter is power on and in the standby mode.
		The inverter is starting up and in the self-check mode.
		The inverter is in normal operation under grid-tied or off-grid modes.
		BACK-UP output overload.
		A fault has occurred.
		The inverter is powered off.
		The grid is abnormal and the inverter is in off-grid mode.
		The grid is normal and the inverter is in grid-tied mode.
		BACK-UP is off.
		The monitoring module of the inverter is resetting.
		The inverter fails to connect with the communication Termination.
		Communication fault between the communication Termination and Server.
		The monitoring of the inverter operates well.
		The monitoring module of the inverter has not been started yet.

8.2 Setting Inverter Parameters via SolarGo App

NOTICE

Please set the inverter parameters first via SolarGo app to ensure its normal operation.

SolarGo App is one smart phone application used to communicate with the inverter via bluetooth, WiFi, 4G or GPRS modules. Commonly used functions:

1. Check the operating data, software version, alarms, etc.
2. Set grid parameters, communication parameters, safety countries, power limitation, etc.
3. Equipment maintenance.
4. Upgrade software version.

For more details, refer to SolarGo User Manual. Scan the QR code or visit https://en.goodwe.com/Ftp/EN/Downloads/User%20Manual/GW_SolarGo_User%20Manual-EN.pdf to get the user manual.



SolarGo App



SolarGo
User Manual

8.3 Monitoring via SEMS Portal

SEMS Portal is a monitoring platform used to communicate with the inverter via WiFi, LAN, 4G, or GPRS. Commonly used functions:

1. Manage the organization or User information;
2. Add and monitor the power plant information;
3. Equipment maintenance.

For more details, refer to SEMS Portal User Manual. Scan the QR code or visit https://en.goodwe.com/Ftp/EN/Downloads/User%20Manual/GW_SEMS%20Portal%20APP_User%20Manual-EN.pdf to get the user manual.



SEMS Portal App



SEMS Portal app
User Manual

9 Maintenance

9.1 Power OFF the Inverter



- Power off the inverter before operations and maintenance. Otherwise, the inverter may be damaged or electric shocks may occur.
- Delayed discharge. Wait until the components are discharged after power off.

Step 1: Turn off the AC breaker on the ON-GRID side of the inverter.

Step 2: Turn off the AC breaker on the BACK-UP side of the inverter.

Step 3: Turn off the battery breaker between the inverter and the battery.

Step 4: Turn off the DC switch of the inverter.

9.2 Removing the Inverter



- Make sure that the inverter is powered off.
- Wear proper PPE before any operations.

Step 1: Disconnect all the cables, including DC cables, AC cables, communication cables, the communication module, and PE cables.

Step 2: Remove the inverter from the mounting plate.

Step 3: Remove the mounting plate.

Step 4: Store the inverter properly. If the inverter needs to be used later, ensure that the storage conditions meet the requirements.

9.3 Disposing of the Inverter

If the inverter cannot work anymore, dispose of it according to the local disposal requirements for electrical equipment waste. The inverter cannot be disposed of together with household waste.

9.4 Troubleshooting

Perform troubleshooting according to the following methods. Contact the after-sales service if these methods do not work.

Collect the information below before contacting the after-sales service, so that the problems can be solved quickly.

1. Inverter information like serial number, software version, installation date, fault time, fault frequency, etc.
2. Installation environment, including weather conditions, whether the PV modules are sheltered or shadowed, etc. It is recommended to provide some photos and videos to assist in analyzing the problem.
3. Utility grid situation.

No.	Fault	Cause	Solutions
1	Utility Loss	<ol style="list-style-type: none"> 1. Utility grid power fails. 2. The AC cable is disconnected, or the AC breaker is off. 	<ol style="list-style-type: none"> 1. The alarm is automatically cleared after the grid power supply is restored. 2. Check whether the AC cable is connected and the AC breaker is on.
2	Grid Overvoltage	The grid voltage exceeds the permissible range, or the duration of high voltage exceeds the requirement of HVRT.	<ol style="list-style-type: none"> 1. If the problem occurs occasionally, the utility grid may be abnormal temporarily. The inverter will recover automatically after detecting that the utility grid is normal. 2. If the problem occurs frequently, check whether the grid voltage is within the permissible range. <ul style="list-style-type: none"> • Contact the local power company if the grid voltage exceeds the permissible range. • Modify the overvoltage protection threshold, HVRT or disable the overvoltage protection function after obtaining the consent of the local power company if the grid frequency is within the permissible range. 3. Check whether the AC breaker and the output cables are connected securely and correctly if the problem persists.

No.	Fault	Cause	Solutions
3	Grid Rapid Overvoltage	The grid voltage is abnormal or ultra-high.	<ol style="list-style-type: none"> 1. If the problem occurs occasionally, the utility grid may be abnormal temporarily. The inverter will recover automatically after detecting that the utility grid is normal. 2. If the problem occurs frequently, check whether the grid voltage is within the allowed range. <ul style="list-style-type: none"> • Contact the local power company if the grid voltage exceeds the permissible range. • Modify the grid overvoltage rapid protection threshold after obtaining the consent of the local power company if the grid voltage is within the permissible range.
4	Grid Undervoltage	The grid voltage is lower than the permissible range, or the duration of low voltage exceeds the requirement of LVRT.	<ol style="list-style-type: none"> 1. If the problem occurs occasionally, the utility grid may be abnormal temporarily. The inverter will recover automatically after detecting that the utility grid is normal. 2. If the problem occurs frequently, check whether the grid voltage is within the permissible range. <ul style="list-style-type: none"> • Contact the local power company if the grid voltage exceeds the permissible range. • Modify the undervoltage protection threshold, LVRT or disable the undervoltage protection function after obtaining the consent of the local power company if the grid frequency is within the permissible range. 3. Check whether the AC breaker and the output cables are connected securely and correctly if the problem persists.

No.	Fault	Cause	Solutions
5	Grid 10min Overvoltage	The moving average of grid voltage in 10min exceeds the range of safety requirements.	<ol style="list-style-type: none"> 1. If the problem occurs occasionally, the utility grid may be abnormal temporarily. The inverter will recover automatically after detecting that the utility grid is normal. 2. If the problem occurs frequently, check whether the grid voltage is within the allowed range. <ul style="list-style-type: none"> • Contact the local power company if the grid voltage exceeds the permissible range. • Modify the grid overvoltage rapid protection threshold after obtaining the consent of the local power company if the grid voltage is within the permissible range.
6	Grid Overfrequency	Utility grid exception. The actual grid frequency exceeds the requirement of the local grid standard.	<ol style="list-style-type: none"> 1. If the problem occurs occasionally, the utility grid may be abnormal temporarily. The inverter will recover automatically after detecting that the utility grid is normal. 2. If the problem occurs frequently, check whether the grid frequency is within the permissible range. <ul style="list-style-type: none"> • Contact the local power company if the grid frequency exceeds the permissible range. • Modify the overfrequency protection threshold or disable the overfrequency protection function after obtaining the consent of the local power company if the grid frequency is within the permissible range.

No.	Fault	Cause	Solutions
7	Grid Underfrequency	Utility grid exception. The actual grid frequency is lower than the requirement of the local grid standard.	<ol style="list-style-type: none"> 1. If the problem occurs occasionally, the utility grid may be abnormal temporarily. The inverter will recover automatically after detecting that the utility grid is normal. 2. If the problem occurs frequently, check whether the grid frequency is within the permissible range. <ul style="list-style-type: none"> • Contact the local power company if the grid frequency exceeds the permissible range. • Modify the underfrequency protection threshold or disable the underfrequency protection function after obtaining the consent of the local power company if the grid frequency is within the permissible range. Or close “Grid Underfrequency” function.
8	Grid Frequency Instability	Utility grid exception. The actual grid frequency change rate does not meet the requirement of the local grid standard.	<ol style="list-style-type: none"> 1. If the problem occurs occasionally, the utility grid may be abnormal temporarily. The inverter will recover automatically after detecting that the utility grid is normal. 2. If the problem occurs frequently, check whether the grid frequency is within the permissible range. <ul style="list-style-type: none"> • Contact the local power company if the grid frequency exceeds the permissible range. • Contact the dealer or the after-sales service if the grid frequency is within the permissible range.
9	Anti-islanding	The utility grid is disconnected. The utility grid is disconnected according to the safety regulations, but the grid voltage is maintained due to the loads.	<ol style="list-style-type: none"> 1. Check whether the utility grid is disconnected. 2. Contact the dealer or the after-sales service.

No.	Fault	Cause	Solutions
10	LVRT Undervoltage	Utility grid exception. The duration of the utility grid exception exceeds the set time of LVRT.	<ol style="list-style-type: none"> 1. If the problem occurs occasionally, the utility grid may be abnormal temporarily. The inverter will recover automatically after detecting that the utility grid is normal. 2. If the problem occurs frequently, check whether the grid frequency is within the permissible range. If not, contact the local power company. If yes, contact the dealer or the after-sales service.
11	HVRT Overvoltage	Utility grid exception. The duration of utility grid exception exceeds the set time of HVRT.	
12	Abnormal GFCI 30mA	The input insulation impedance becomes low when the inverter is working.	<ol style="list-style-type: none"> 1. If the problem occurs occasionally, it may be caused by a cable exception. The inverter will recover automatically after the problem is solved. 2. Check whether the impedance between the PV string and PE is too low if the problem occurs frequently or persists.
13	Abnormal GFCI 60mA		
14	Abnormal GFCI 150mA		
15	Abnormal GFCI		
16	Large DC of AC current L1	The DC component of the output current exceeds the safety range or default range.	<ol style="list-style-type: none"> 1. If the problem is caused by an external fault like a utility grid exception or frequency exception, the inverter will recover automatically after solving the problem. 2. If the problem occurs frequently and the PV station cannot work properly, contact the dealer or the after-sales service.
17	Large DC of AC current L2		
18	Low Insulation Res.	<ol style="list-style-type: none"> 1. The PV string is short-circuited to PE. 2. The PV system is in a moist environment and the cable is not well insulated to the ground. 	<ol style="list-style-type: none"> 1. Check whether the resistance of the PV string to PE exceeds 50kΩ. If no, check the short circuit point. 2. Check whether the PE cable is connected correctly. 3. If the resistance is lower on rainy days, please reset the ISO.

No.	Fault	Cause	Solutions
19	Abnormal Ground	<ol style="list-style-type: none"> 1. The PE cable of the inverter is not connected well. 2. The L cable and N cable are connected reversely when output of the PV string is grounded. 	<ol style="list-style-type: none"> 1. Check whether the PE cable of the inverter is connected properly. 2. Check whether the L cable and N cable are connected reversely if output of the PV string is grounded.
20	Anti Reverse power Failure	Abnormal fluctuation of load	<ol style="list-style-type: none"> 1. If the exception is caused by an external fault, the inverter will recover automatically after solving the problem. 2. If the problem occurs frequently and the PV station cannot work properly, contact the dealer or the after-sales service.
21	Internal Comm Loss	<ol style="list-style-type: none"> 1. Frame format error 2. Parity checking error 3. Can bus offline 4. Hardware CRC error 5. Send (receive) control bit is receive (send). 6. Transmit to the unit that is not allowed. 	<p>Disconnect the AC output switch and DC input switch, then connect them 5 minutes later. Contact the dealer or the after-sales service if the problem persists.</p>
22	AC HCT Check abnormal	The sampling of the AC HCT is abnormal.	<p>Disconnect the AC output switch and DC input switch, then connect them 5 minutes later. Contact the dealer or the after-sales service if the problem persists.</p>
23	GFCI HCT Check abnormal	The sampling of the GFCI HCT is abnormal.	<p>Disconnect the AC output switch and DC input switch, then connect them 5 minutes later. Contact the dealer or the after-sales service if the problem persists.</p>

No.	Fault	Cause	Solutions
24	Relay Check abnormal	<ol style="list-style-type: none"> 1. The relay is abnormal or short-circuited. 2. The control circuit is abnormal. 3. The AC cable connection is abnormal, like a virtual connection or short circuit. 	<p>Disconnect the AC output switch and DC input switch, then connect them 5 minutes later. Contact the dealer or the after-sales service if the problem persists.</p>
26	Flash Fault	<p>The internal Flash storage is abnormal.</p>	<p>Disconnect the AC output switch and DC input switch, then connect them 5 minutes later. Contact the dealer or the after-sales service if the problem persists.</p>
27	DC Arc Fault	<ol style="list-style-type: none"> 1. The DC terminal is not firmly connected. 2. The DC cable is broken. 	<p>Read the Quick Installation Guide and check whether the cables are connected properly.</p>
28	AFCI Self-test Fault	<p>AFCI detection is abnormal.</p>	<p>Disconnect the AC output switch and DC input switch, then connect them 5 minutes later. Contact the dealer or the after-sales service if the problem persists.</p>
29	Cavity Overtemperature	<ol style="list-style-type: none"> 1. The inverter is installed in a place with poor ventilation. 2. The ambient temperature exceeds 60°C. 3. A fault occurs in the internal fan of the inverter. 	<ol style="list-style-type: none"> 1. Check the ventilation and the ambient temperature at the installation point. 2. If the ventilation is poor or the ambient temperature is too high, improve the ventilation and heat dissipation. 3. Contact the dealer or after-sales service if both the ventilation and the ambient temperature are normal.

No.	Fault	Cause	Solutions
30	BUS Overvoltage	1. The PV voltage is too high. 2. The sampling of the inverter BUS voltage is abnormal.	Disconnect the AC output switch and DC input switch, then connect them 5 minutes later. Contact the dealer or the after-sales service if the problem persists.
31	PV Input Overvoltage	The PV array configuration is not correct. Too many PV panels are connected in series in the PV string.	Check the serial connection of the PV array. Make sure that the open circuit voltage of the PV string is not higher than the maximum operating voltage of the inverter.
32	PV Continuous Hardware Overcurrent	1. The PV configuration is not proper. 2. The hardware is damaged.	Disconnect the AC output switch and DC input switch, then connect them 5 minutes later. Contact the dealer or the after-sales service if the problem persists.
33	PV Continuous Software Overcurrent	1. The PV configuration is not proper. 2. The hardware is damaged.	Disconnect the AC output switch and DC input switch, then connect them 5 minutes later. Contact the dealer or the after-sales service if the problem persists.
34	String1 PV String Reversed	The PV string is connected reversely.	Check whether the PV1 and PV2 strings are connected reversely.
35	String2 PV String Reversed		

9.5 Routine Maintenance

WARNING

- Make sure that the inverter is powered off.
- Wear proper PPE before any operations.

Maintaining Item	Maintaining Method	Maintaining Period
System Clean	Check the heat sink, air intake, and air outlet for foreign matter or dust.	Once 6-12 months
DC Switch	Turn the DC switch on and off ten consecutive times to make sure that it is working properly.	Once a year
Electrical Connection	Check whether the cables are securely connected. Check whether the cables are broken or whether there is any exposed copper core.	Once 6-12 months
Sealing	Check whether all the terminals and ports are properly sealed. Reseal the cable hole if it is not sealed or too big.	Once a year
THDi Test	For Australia requirements, in the THDi test, there should add Zref between inverter and mains. L: $0.24 \Omega + j0.15 \Omega$; N: $0.16 \Omega + j0.10 \Omega$ L: $0.15 \Omega + j0.15 \Omega$; N: $0.1 \Omega + j0.1 \Omega$	As needed.

10 Technical Parameters

Technical Data	GW15K-ET	GW20K-ET	GW25K-ET	GW29.9K-ET	GW30K-ET
Battery Input Data					
Battery Type	Li-Ion				
Nominal Battery Voltage (V)	500				
Battery voltage range (V)	200~800				
Start-up Voltage (V)	180				
Number of Battery Input	1		2		
Max. Continuous Charging Current (A)	50		50×2		
Max. Continuous Discharging Current (A)	50		50×2		
Max Charge Power (W)	15,000	20,000	25,000	30,000	30,000
Max Discharge Power (W)	15,000	20,000	25,000	30,000	30,000
PV String Input Data					
Max. Input Power (W) ^{*1}	22,500	30,000	37,500	45,000	45,000
Max. Input Voltage (V) ^{*2}	1000				
MPPT Operating Voltage Range (V)	200~850				
MPPT Voltage Range at Nominal Power (V) ^{*3}	400~850	400~850	450~850	450~850	450~850
Start-up Voltage (V)	200				
Nominal Input Voltage (V)	620				
Max. Input Current per MPPT (A)	30				
Max. Short Circuit Current per MPPT (A)	38				
Number of MPPT	2	2	3	3	3
Number of Strings per MPPT	2/2	2/2	2/2/2	2/2/2	2/2/2
AC Output Data (On-grid)					
Nominal Output Power (W)	15,000	20,000	25,000	29,900	30,000

Technical Data	GW15K-ET	GW20K-ET	GW25K-ET	GW29.9K-ET	GW30K-ET
Max. Output Power (W)	16,500	22,000	27,500	29,900	33,000
Nominal Apparent Power Output to Utility Grid (VA)	15,000	20,000	25,000	29,900	30,000
Max. Apparent Power Output to Utility Grid (VA) ^{*3}	16,500	22,000	27,500	29,900	33,000
Nominal Apparent Power from Utility Grid(VA)	15,000	20,000	25,000	30,000	30,000
Max. Apparent Power from Utility Grid (VA)	22,500	30,000	33,000	33,000	33,000
Nominal Output Voltage (V)	380/400, 3L/N/PE				
Output Voltage Range (V) ^{*4}	0~300				
Nominal AC Grid Frequency (Hz)	50/60				
AC Grid Frequency Range (Hz)	45~65				
Max. AC Current Output to Utility Grid (A) ^{*11}	25.0	33.3	41.7	49.8	50.0
Max. AC Current From Utility Grid (A)	34.0	45.0	50.0	50.0	50.0
Nominal AC Current From Utility Grid (A)	25.0	33.3	41.7	50.0	50.0
Max. Output Fault Current (Peak and Duration) (A)	241.5A@126ms				
Inrush Current (Peak and Duration) (A)	264A@53us				
Nominal Output Current (A) ^{*5}	22.7	30.3	37.9	45.3	45.5
Power Factor	~1 (Adjustable from 0.8 leading~0.8 lagging)				
Max. Total Harmonic Distortion	<3%				
Maximum Output Overcurrent Protection (A)	94				
AC Output Data (Back-up)					
Back-up Nominal Apparent Power (VA)	15,000	20,000	25,000	29,900	30,000

Technical Data	GW15K-ET	GW20K-ET	GW25K-ET	GW29.9K-ET	GW30K-ET
Max. Output Apparent Power Without Grid (VA)*6	15,000 (18,000 @60s , 24,000 @3s)	20,000 (24,000 @60s , 32,000 @3s)	25,000 (30,000 @60sec)	30,000 (36,000 @60sec)	30,000 (36,000 @60sec)
Max. Output Apparent Power with Grid (VA)	15,000	20,000	25,000	29,900	30,000
Nominal Output Current (A)	22.7	30.3	37.9	45.5	45.5
Max. Output Current (A)	22.7 (27.3 @60s, 36.4 @3s)	30.3 (36.4 @60s, 48.5 @3s)	37.9 (45.5 @60s)	45.5 (54.5 @60s)	45.5 (54.5 @60s)
Max. Output Fault Current (Peak and Duration) (A)	94				
Inrush Current (Peak and Duration) (A)	264@53us				
Maximum Output Overcurrent Protection (A)	94				
Nominal Output Voltage (V)	380/400				
Nominal Output Frequency (Hz)	50/60				
Output THDv (@Linear Load)	<3%				
Efficiency					
Max. Efficiency	98.0%				
European Efficiency	97.5%				
Max. Battery to AC Efficiency	97.5%				
MPPT Efficiency	99.9%				
Protection					
PV String Current Monitoring	Integrated				
PV Insulation Resistance Detection	Integrated				
Residual Current Monitoring	Integrated				
PV Reverse Polarity Protection	Integrated				

Technical Data	GW15K-ET	GW20K-ET	GW25K-ET	GW29.9K-ET	GW30K-ET
Battery Reverse Polarity Protection	Integrated				
Anti-islanding Protection	Integrated				
AC Overcurrent Protection	Integrated				
AC Short Circuit Protection	Integrated				
AC Overvoltage Protection	Integrated				
DC Switch ^{*7}	Integrated				
DC Surge Protection	Type II				
AC Surge Protection	Type III				
AFCI	Optional				
Rapid Shutdown	Optional				
Remote Shutdown	Integrated				
General Data					
Operating Temperature Range (°C)	-35~+60				
Relative Humidity	0~95%				
Max. Operating Altitude (m)	4000				
Cooling Method	Smart Fan Cooling				
Display	LED, WLAN+APP				
Communication with BMS	RS485 / CAN				
Communication with Meter	RS485				
Communication with Portal	WiFi / 4G				
Weight (kg)	48	48	54	54	54
Dimension W×H×D (mm)	520×660×220				
Noise Emission (dB)	<45	<45	<45	<60	<60
Topology	Non-isolated				
Self-consumption at Night (W) ^{*8}	<15				
Ingress Protection Rating	IP66				
DC Connector	MC4				

Technical Data	GW15K-ET	GW20K-ET	GW25K-ET	GW29.9K-ET	GW30K-ET
AC Connector	OT				
Environmental Category	4K4H				
Pollution Degree	III				
Overvoltage Category	DC II / AC III				
Protective Class	I				
Storage Temperature (°C)	-45~+85				
The Decisive Voltage Class (DVC)	Battery: C PV: C AC: C Com: A				
Mounting Method	Wall Mounted				
Active Anti-islanding Method	AFDPF + AQDPF *9				
Type of Electrical Supply System	Three phase Grid				
Country of Manufacture	China				
Certification *10					
Grid Standards	VDE-AR-N 4105,EN50549-1				
Safety Regulation	IEC62619-1/-2				
EMC	EN61000-6-1, EN61000-6-2, EN61000-6-3, EN61000-6-4				
<p>*1: Max. Input Power, not continuous for 1.5*normal power. *2: For 1000V system, Maximum operating voltage is 950V. *3: According to the local grid regulation. *4: Output Voltage Range: phase voltage. *5: For 400V grid (such as Australia, Germany, etc.), the Nominal Output Current is 21.7A for GW15K-ET, 29.0A for GW20K-ET, 36.2A for GW25K-ET, 43.3A GW29.9K-ET, 43.5A for GW30K-ET. *6: Can be reached only if PV and battery power is enough. *7: DC Switch: GHX6-55P (for Australia). *8: No Back-up Output. *9: AFDPF: Active Frequency Drift with Positive Feedback, AQDPF: Active Q Drift with Positive Feedback. *10: Not all certifications & standards listed, check the official website for details. *11: For 400V grid (such as Australia, Germany, etc.), the Max. AC Current Output to Utility Grid is 23.9A for GW15K-ET, 31.9A for GW20K-ET, 39.9A for GW25K-ET, 43.3A for GW29.9K-ET, 47.8A for GW30K-ET.</p>					



Official
Website

GoodWe Technologies Co., Ltd.

 No. 90 Zijin Rd., New District, Suzhou, 215011, China

 www.goodwe.com

 service@goodwe.com



Local Contacts