

3DIM Tool 2.3.1

Operating instructions

XII 2013

Light is OSRAM



Contents

Description	4	Password visualisation	22
Purpose and application	4	Upload/Download	23
What is 3DIM?	4	Uploading a configuration	23
DALI® – Digital communication	4	Downloading a configuration	24
StepDIM – Midnight step-down / Half-night switch	4	Configuration handling	25
AstroDIM – Dimming without external control	4	Saving a configuration	25
		Loading a configuration	25
Installation	5	Monitoring	26
System requirements	5	Reset	27
Software installation	5	Reset 3DIM parameters	27
Hardware installation	6	Delete AstroDIM power-on history	27
Wiring diagram	6	Reset LED module operating time	28
User interface	7	Settings	28
Basic layout	7	Display preferences	28
Menu bar	7	Defining coordinate formats	30
Toolbar	8	Manufacturing mode	30
3DIM ECG and 3DIM mode selection	9	Report	33
Workspaces	9	Utilizing 3DIM Tool in Production	35
Status bar	9	General	35
		Installing 3DIM Tool	35
General Operation	10	Programming 3DIM ECG(s)	35
Principle	10	Troubleshooting	37
Selecting ECG type and 3DIM mode	10	General error handling	37
StepDIM mode	11	More than one DALI magic connected.	38
StepDIM Parameter setting	11	Upload failed. The connected ECG differs from the 3DIM Tool selection.	38
StepDIM Visualisation	12		
AstroDIM mode	12		
Location selection	12		
Selection of summer/winter time (daylight saving time)	15		
AstroDIM parameter setting	15		
Energy savings display	16		
AstroDIM Visualisation	16		
OPTOTRONIC® Config	18		
Current Setting Module (CSM)	18		
Constant Lumen Module (CLM)	19		
Temperature Protection Module (TPM)	20		
OPTOTRONIC® Config password protection	21		
Setting a password	21		
Changing a password	22		
Deleting (resetting) a password	22		

Version:

Dec. 2013

Please note:

All information in this manual has been prepared with great care. OSRAM, however, does not accept liability for possible errors, changes and/ or omissions. Please check www.osram.com or contact your sales partner for an updated copy of this manual.

Software updates:

To ensure the latest software version is used please consult the OSRAM website www.osram.com/3DIM in regular intervals (once a month). New versions will be released due to software improvements, additional supported devices and bug fixing.

Description

Purpose and application

The "3DIM Tool" software is utilized for programming electronic control gears (ECG) from OSRAM equipped with the 3DIM functionality. The connection between PC and ECG is established via the "DALI magic" hardware interface from OSRAM.

OSRAM 3DIM ECG families are:

- POWERTRONIC® 3DIM ECG for high pressure discharge lamps
- OPTOTRONIC® 3DIM ECG for LED modules

What is 3DIM?

3DIM embodies the combination of three different control and dimming options in one OSRAM ECG.

DALI® – Digital communication

3DIM ECG can be integrated in bidirectional telemanagement systems via the DALI® interface. DALI® is a manufacturer-independent, well-proven communication standard specifically developed for lighting applications.

StepDIM – Midnight step-down / Half-night switch

StepDIM is used in installations, where a dedicated high voltage control line (switched phase) in addition to the mains supply is available. This additional phase is connected to the StepDIM port (SD terminal) of the ECG. For StepDIM two switching logics are available:

- StepDIM
 - Control line not live equals default value (Power-on level)
 - Control line live equals Dim level
- StepDIM inverse
 - Control line live equals default value (Power-on level)
 - Control line not live equals Dim level

AstroDIM – Dimming without external control

AstroDIM is ideal if there is no way to dim the ECG by dedicated control lines (DALI® or StepDIM interface not available) due to a lack of infrastructure. It allows autonomic dimming in two steps via an integrated time actuator (no real time clock).

More information on 3DIM as well as a detailed application guide is available at www.osram.com/3dim.

Note:

The 3DIM Tool is used only for the configuration of StepDIM, AstroDIM and some specific parameters for OPTOTRONIC® constant current ECGs. It is not possible to send individual DALI® commands with 3DIM Tool. For this purpose OSRAM offers the DALI wizard software, which is also used in combination with a DALI magic. www.osram.com/lms-magic

Installation

System requirements

The minimum system requirements for the 3DIM Tool are:

- OSRAM DALI magic incl. USB cable
- A PC or notebook with the following specification
 - Pentium M processor
 - 1 GB main memory
 - Windows XP, Windows Vista or Windows 7 (both 32 or 64-bit)
 - 40 MB hard disk memory
 - Monitor with a resolution of 1024x768 or 1024x600 pixels, the recommended zoom factor is 100 %
 - A free USB 2.0 port

Software installation

3DIM Tool can be downloaded via www.osram.com/3dim. After the download, the 3DIM Tool appears as ZIP file in download folder.



Two different versions of the 3DIM Tool can be installed:

- Normal mode: All configuration features are available.
- Manufacturing mode: Only prepared configurations can be uploaded.

Normal mode is designed for creating configurations as well as testing 3DIM and OPTOTRONIC® Config parameters during luminaire development, or installation design. Manufacturing mode is set-up for usage in production, only enabling the upload of a predefined configuration. It is recommended to install only manufacturing mode on PCs utilized in production.

Step	Activity
1	Double-click the ZIP file.
2	Within the ZIP folder, double-click the setup file. The installation wizard appears.
3	Follow the instructions of the installation wizard.

3DIM Tool is executed via "Start" → "All Programs" → "OSRAM" → "3DIM Tool" or by double-clicking the desktop icon (normal or manufacturing mode).

Hardware installation

To program OSRAM 3DIM ECG(s), a connection between ECG(s) and PC must be established first. It is possible to program up to 64 ECGs of the same type simultaneously.

Step	Activity
1	Connect DALI magic and PC with the enclosed USB cable.
2	If more than 4 ECGs are programmed simultaneously, the external 6 V DC power supply for the DALI magic must be used ¹ .
3	Connect the OSRAM 3DIM ECG to mains.
4	Connect the DALI [®] terminals of the DALI magic with the DALI [®] inputs of the ECG(s).

Note:

It is recommended to disconnect the USB connection between PC and DALI magic only after closing the 3DIM Tool.

Wiring diagram

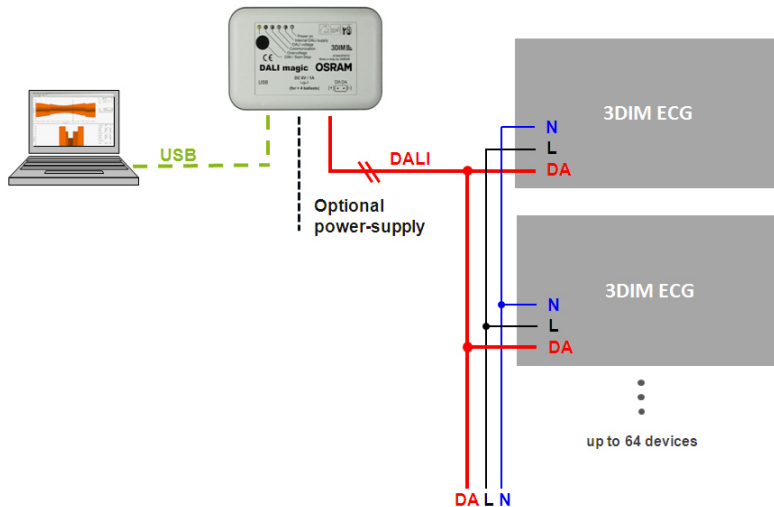

¹ Up to 4 ECGs can be programmed without external power supply only if no other USB devices are connected to the PC (USB port overload needs to be avoided).

User interface

Basic layout

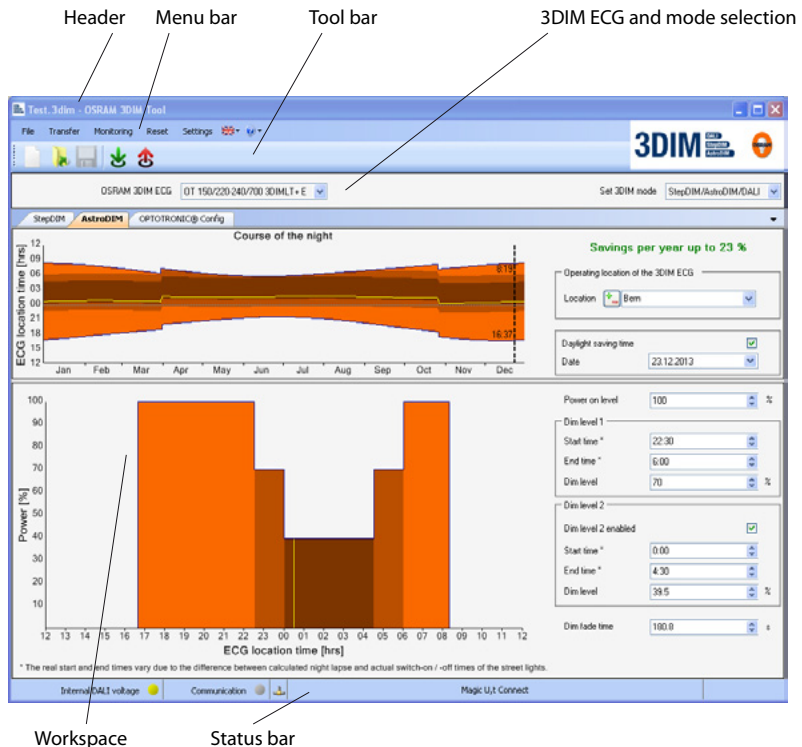

Menu bar

The basic functions are available via the menu bar. Submenus or dialogs are opened by clicking an entry in the menu bar. The menu contains the following elements, each with the listed sub items.

File

New configuration	Creates a new configuration.
Load configuration...	Loads an existing configuration.
Save	Saves the current configuration.
Save as...	Saves the current configuration under a new name.
Exit	Closes the software.

Transfer

Upload to ECG(s)	Sends the current configuration to the ECGs.
Download from ECG	Displays the configuration of the ECG connected (only possible with one ECG) within the user interface.

Monitoring

Opens the Monitoring window.

Settings

Opens the Settings menu.

Reset

Reset 3DIM parameters	Restores 3DIM factory settings.
Delete AstroDIM power-on history	Deletes AstroDIM operating hour memory.
Reset LED module operating time	Resets the LED module operating time to „0“ (Only possible for OPTOTRONIC® constant current ECG).

Note:

Each reset requires a restart (disconnecting and reconnecting the power supply) of the ECG.

Flag icon





Allows for selecting the GUI language. After the language has been changed, a restart of 3DIM Tool is necessary.

Help Icon

About OSRAM 3DIM Tool... | Opens the About dialog.

Toolbar

The toolbar provides instant access to the most important features.

	New configuration	Creates a new configuration.
	Load configuration...	Loads an existing configuration.
	Save	Saves the current configuration.
	Upload to ECG(s)	Sends the current configuration to the ECG(s).
	Download from ECG	Displays the configuration of the ECG connected (only possible with one ECG) within the user interface.

3DIM ECG and 3DIM mode selection

The three drop-down menus are used for selecting the utilized 3DIM ECG and operation mode.

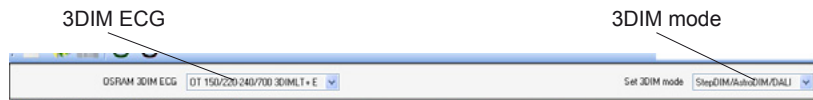

Workspaces

The tabs are used to switch between “StepDIM”, “AstroDIM” and “OPTOTRONIC® Config” workspaces. At any given time only workspaces are shown, which are supported by the chosen ECG and operating mode.

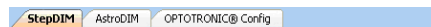

Status bar

At the bottom of the 3DIM Tool all information regarding the current state is displayed.





DALI magic power supply

- No DALI® voltage, this is only displayed if no DALI magic is connected.
- A yellow mark indicates that the DALI magic is only supplied by the USB port, thus only 4 ECGs can be programmed simultaneously.
- A green mark indicates that the DALI magic is supplied via the external power supply, up to 64 ECGs can be programmed.
- A red mark indicates that the voltage on the connection terminals of the connected DALI Magic is higher than the maximum permitted DALI® voltage.

Communication state

- A blue mark indicates communication via the DALI® line.

USB connection

-  DALI magic not connected to USB.
-  DALI magic connected to USB.

Status note

The message displayed summarizes the current state and task executed.

Progress bar

During search, upload or download, the progress of the executed task is displayed here.

General Operation

Principle

3DIM Tool is designed to immediately visualise parameter changes made by the user. This display provides the user with an indication how the 3DIM ECG will behave in subsequent operation.

The steps described below can be carried out in any order, although for OPTOTRONIC® constant current devices it is recommended to first set-up the OPTOTRONIC® Config parameters.

Selecting ECG type and 3DIM mode

Note:

For a detailed description of the 3DIM modes, please refer to the 3DIM application guide www.osram.com/3dim.

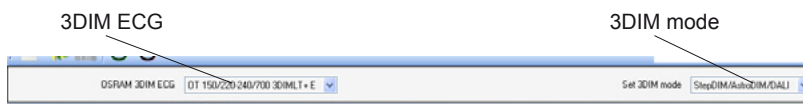

3DIM ECG type

The utilized 3DIM ECG is selected via the left drop-down menu.

3DIM mode

Depending on the selected ECG different 3DIM modes (right drop-down menu) are available. To be compliant with the DALI® standard, each 3DIM mode includes the possibility to control the ECG via DALI® commands.

- **StepDIM/AstroDIM/DALI (wiring selection)**
The wiring of the ECG decides whether StepDIM, AstroDIM or DALI® mode is performed, after switching on the ECG. (For the different wiring schemes, please refer to the ECG data sheet or the 3DIM application guide.)
- **StepDIM/DALI**
StepDIM as well as DALI® can be used.
- **StepDIM inverse/DALI**
StepDIM inverse as well as DALI® can be used.
- **AstroDIM/DALI**
AstroDIM as well as DALI® can be used.
- **DALI**
Only DALI® can be used.

StepDIM mode

Select the "StepDIM" tab to configure StepDIM. The workspace consists of the parameter setting frame and the visualization of the ECG behaviour.

StepDIM Parameter setting

Power-on level	100	%
Dim level 1		
Dim level	80	%
Dim fade time	181.0	s

StepDIM operation is defined by three parameters.

- Power-on level in [%]:
Output power level (in % of the nominal value of the ECG lamp combination), after switch-on via mains. The settable minimum value is limited according to the capabilities of the chosen ECG. The Power On Level in the 3DIM Tool corresponds to the DALI® Power On level and System Failure Level.
- Dim level in [%]:
Output power level (in % of the nominal value of the ECG lamp combination), after the control wire is switched (SD state change). The Dim level may be lower, equal to or higher than the Power-on level. The settable minimum value is limited according to the capabilities of the chosen ECG.
- Dim fade time in [s]:
Transition time between Power-on level and Dim level and vice versa (only configurable for OPTOTRONIC® 3DIM ECG).

Note:

Both the Power-on level and the Dim level are set according to the logarithmical dimming curve of the DALI® standard. For a detailed description, please see IEC62386-102, table 9.1. If DIM level or the Power On Level is below the physical min level of the ECG, the physical min level would be used.

StepDIM Visualisation

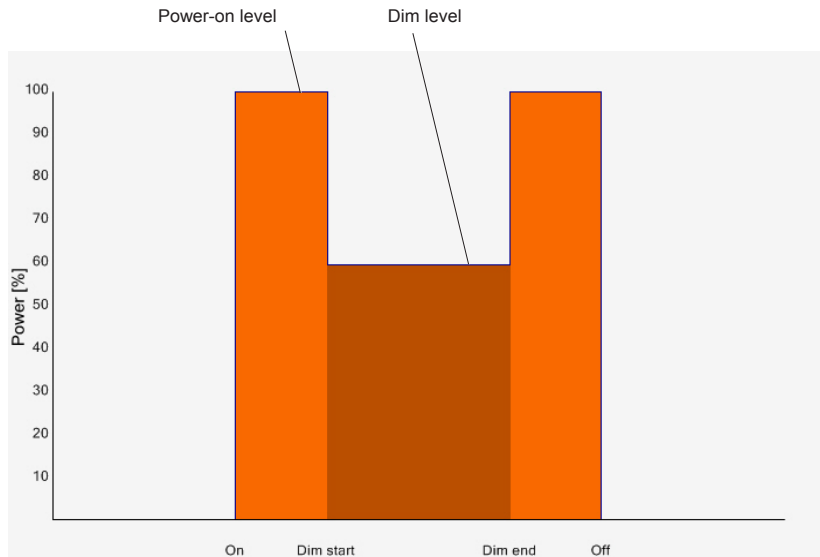

StepDIM: ECG behaviour during the night

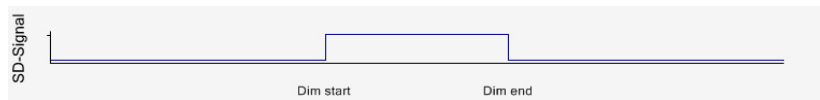

StepDIM: Rendition of the SD state change in "StepDIM/DALI" mode

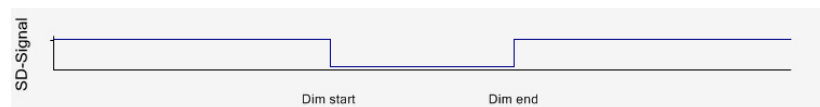

StepDIM: Rendition of the SD state change in "StepDIM inverse/DALI" mode

AstroDIM mode

Select the "AstroDIM" tab to configure AstroDIM. The workspace includes the setting and visualization of the ECG operating location, as well as of the ECG behaviour.

Location selection

Note:

To configure AstroDIM the operation location of the ECG must be specified first.

To do so, either select a default location within the locations drop-down menu or create a new location. Predefined location could not be modified. In the case the location data in the ECG is not matching with any predefined location "customized" will be shown.

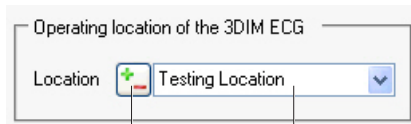

Change/Create location Location selection

The coordinates and the time zone for each location could be visualized by moving the mouse above the drop down menu arrow.

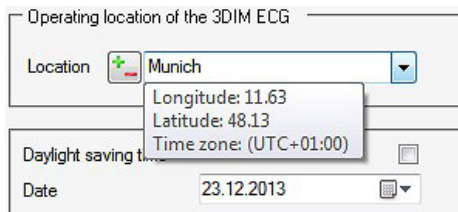

Creating a location

To create a location, click the button to the left of location drop-down menu. The “ECG location” dialog opens. The coordinates and the time zone for each location could be visualized by moving the mouse above the drop down menu arrow

Location visualization

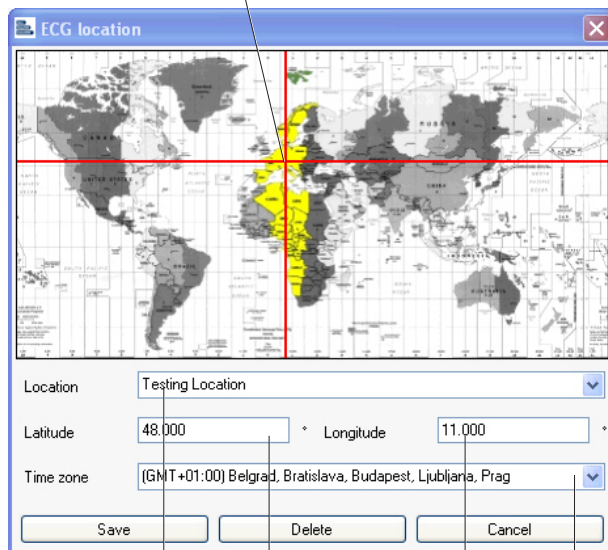

Location name Latitude Longitude Time zone

Each location is defined by the following properties:

- Location name
- Latitude
- Longitude
- Time zone

Latitude and longitude are entered in decimal form with up to four decimal places as standard. Admissible input values for latitude are values between -65.000 and 65.000 for longitude between -180.000 and 180.000.

In addition to the decimal input, the coordinates can also be entered in degrees and minutes, herefore the input method must be changed accordingly, within the settings menu (see chapter "Settings").

Coordinate examples:

	Latitude	Longitude	Latitude as decimal value	Longitude as decimal value
Munich	48° 8' N	11° 34' E	48.1397	11.5744
New York	40° 42' N	74° 0' W	40.7127	-74.0058
Sydney	33° 51' S	151° 12' E	-33.8500	151.2000

If the geographical coordinates for a given ECG operating location are not available, they can be determined, amongst others, in the following ways.

Determining decimal coordinates via Google maps

Step	Activity
1	In your web browser, open the following website: http://maps.google.com/
2	Enter the location (i.e. the name of a city) you are seeking into the search field and click "Search Maps".
3	Right-click on the location of the ECG within the map and select "What's here?" in the context menu.
4	The coordinates are displayed in decimal form as "Latitude, Longitude" in the search field.

Determining coordinates via Wikipedia

Step	Activity
1	In your web browser, open the following website: http://en.wikipedia.org/
2	Enter the location (i.e. the name of a city) you are seeking into the search field at the top right corner and confirm with the return key.
3	The Wikipedia entry of the location opens; the coordinates are displayed in degrees and minutes directly below the search field. A left-click on the coordinates opens a new browser window; here the coordinates are also displayed in decimal form.

Create location

Step	Activity
1	Open the "ECG location" dialog.
2	Include location name, latitude and longitude.
3	During the input of the coordinates, a pre-selection of the time zone is made. Please check if the time zone is correct and change it if necessary. By default only one entry per time zone is available within the drop-down menu. This can be changed within the settings menu.
4	Click "Save" to adopt the new location into the location drop-down menu.

Edit location

Step	Activity
1	Open the "ECG location" dialog.
2	Select the respective location within the drop-down menu.
3	Edit the location parameters.
4	Click „Save“.

Delete location

Step	Activity
1	Open the "ECG location" dialog.
2	Select the respective location within the drop-down menu.
3	Click „Delete“.

Selection of summer/winter time (daylight saving time)

Setting or removing the "Daylight saving time" tick only mark changes the visualisation of the night lapse accordingly and the start and end times for the two dimming levels and the selected day. The ECG parameters for the dimming profile are not affected.. This is to indicate how the device will behave during daylight saving time.

Daylight saving time

AstroDIM parameter setting

The AstroDIM operation is individually configured by means of the following parameters.

- Power-on level in [%]:
Output power level (in % of the nominal value of the ECG lamp combination), after switch-on via mains. The settable minimum value is limited according to the capabilities of the chosen ECG. The Power On Level in the 3DIM Tool corresponds to the DALI® Power On level and System Failure Level.
- Dim fade time in [s]:
Transition time between Power-on level and Dim level and vice versa (only configurable for OPTOTRONIC® 3DIM ECG).

- Two dimming levels, with the second level being optional. Each level is defined by:
 - Start time in [hh:mm]: Time at which the dimming level starts².
 - End time in [hh:mm]: Time at which the ECG changes to the next level².
 - Dim level in [%]:
Output power level (in % of the nominal value of the ECG lamp combination), for the respective dimming level. A level must not necessarily be lower than the Power-on level or the previous dimming level. The settable minimum value is limited according to the capabilities of the chosen ECG.

Note:

Both the Power-on level and the Dim levels are set according to the logarithmical dimming curve of the DALI[®] standard. For detailed description, please see IEC62386-102, table 9.1. If DIM level or the Power On Level are below the physical min level of the ECG, the physical min level will be used.

Power-on level	100	%
Dim level 1		
Start time *	21:56	
End time *	3:56	
Dim level	80	%
Dim level 2		
Dim level 2 enabled	<input checked="" type="checkbox"/>	
Start time *	0:00	
End time *	2:00	
Dim level	60	%
Dim fade time	181.0	s

Energy savings display

3DIM Tool estimates the maximum annual savings in [%], which can be achieved by using AstroDIM. This estimation is based on the assumption that the ECG is operated according to the ideal night as it is displayed within the AstroDIM night lapse visualisation and the minimum dimming level is above or equal the Physical Min Level

Savings per year up to 10 %

AstroDIM Visualisation

The top graph shows the night sequence over the year at the selected ECG location. Sunsets are represented by the lower line and sunrises are represented by the upper line. The night, therefore, corresponds to the enclosed, light orange area.

The arithmetic mean of the night is represented by the yellow line. The darker areas correspond to the times at which the ECG is operated in the first or second dimming level.

² If the real switch-on / -off times differ from the sunset and sunrise depicted in 3DIM Tool (course of the night visualisation), the dim start and end may also vary according to this offset. For a detailed description of the AstroDIM behavior, please refer to the 3DIM application guide. The displayed start- and end times could differ between +/- 2,5 minutes between the uploaded and the downloaded data due to the conversion accuracy of the ECG. The devices of the PTo family and the OT 65 3DIM the values could differ much more, because the location data and the reference date could not be stored on those ECGs.

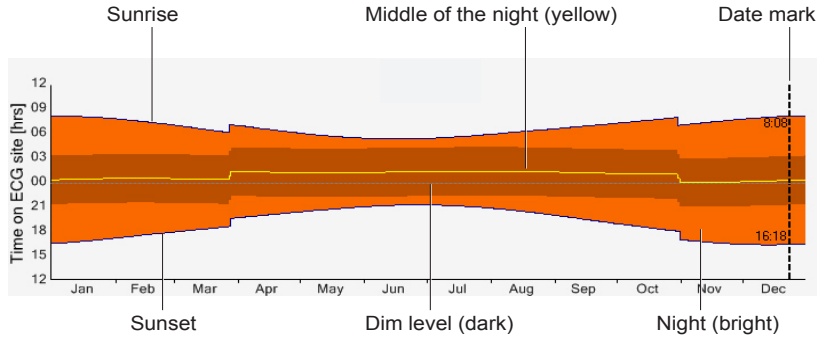

AstroDIM: Night sequence over the year at the selected ECG location

The date mark shows the sunrise and sunset for a certain day. By default the date mark is located at the day with the longest night. To display the times for another day, select the respective date in the “Date” drop-down menu.

Daylight saving time

Date ▼

The lower diagram visualizes the ECG behavior on the selected day. The switch-on and switch-off times are adopted from the chosen date. While adjusting the dimming sequences it is recommended to check the dimming behavior at the longest and shortest day of the year. The displayed start and end times for the two dimming levels will be converted into the ECG programming parameters, which are referenced to the half operating time (middle of the night; yellow line) for this selected day. The time shift between midnight (00:00) and the half operating time (middle of the night) vary over the year and cause a variation of the dimming periods. Therefore changing the date influences the specific AstroDIM programming parameters stored in ECG.

The displayed start and end times for each dimming level are only valid, if the switch on and off time for the ECG correspond with sunset and sunrise depicted in the 3DIM Tool.

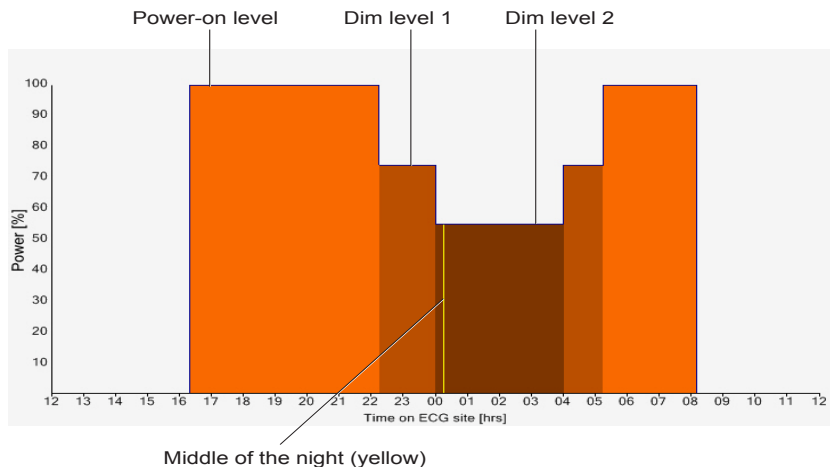

OPTOTRONIC® Config

The features displayed within the “OPTOTRONIC® Config” tab, max. operating current setting (CSM), constant lumen output (CLM) and temperature protection module (TPM) are only settable for OPTOTRONIC® constant-current power supplies.

Note:

It is recommended to finish the OPTOTRONIC® Config settings before setting AstroDIM and StepDIM parameters, since a variation of the max. operating current or the constant lumen function could impact the Dim level minimum (percentage).

Current Setting Module (CSM)

Current Setting Module (CSM)	
Maximum rated current	700 mA
Max. operating current	700 mA
Minimum rated current	350 mA
Minimal dimming current	75 mA
LEDset protection enabled	<input checked="" type="checkbox"/>

The current setting module defines the nominal maximum operating current of the LED power supply. This current can be set according to the demand and capability of the LED module(s). Max. operating currents outside the rated range of the power supply are indicated in red. Within CSM, the following parameters can be configured.

- Max. operating current in [mA]:
The max. operating current can be varied between the minimum rated current and the maximum rated current in steps of 1 mA. The useable operating current range varies with the capabilities of the selected ECG. If the max. Operating current is out of the rated range, it would be displayed in red.
- LEDset Protection enabled:
LEDset is an interface between LED modules and OPTOTRONIC® constant-current LED power supplies. It allows setting the output current of the electronic control gear (ECG) according to the needs of the LED module or LED luminaire. In case the LEDset interface wiring to the LED module is interrupted, the ECG switches into LEDset protection mode, thus preventing damaging of the LED module.
This mode can be enabled or disabled by setting the respective checkmark. If the LEDset port is not used, it is recommended to disable the LEDset protection.

Note:

For a detailed description of LEDset, please refer to the LEDset application guide. www.osram.com/LEDset

Constant Lumen Module (CLM)

Constant Lumen Module (CLM)

CLM enabled

70	80	85	90	95	100			%	%
0	10	20	30	40	50			kHrs	kHrs

Set LED module operating time 0 kHrs

The constant lumen feature is utilized to compensate the depreciation of the luminous flux of a LED module over life time.

The following parameters are used to define the adjustment of the depreciation:

- A checkbox to (de)activate the feature.
- A look-up table for up to 8 data points consisting of the LED module operation time in [kHrs] and the relative output level of the max. operating current in [%]. The valid range for the LED module operating time is 0 to 254 kHrs, for the operating current output level it is 70 to 100 %.
- A checkbox and input field in [kHrs] for setting the LED module operating time within the ECG. Only if the checkbox is ticked, the value of the input field is written to the ECG. The valid range for the LED module operating time is 0 to 254 kHrs.

A new data point is added to the look-up table once a start time in [kHrs] is included; a data point is deleted once its start time is deleted.

Note:

In case an installed LED module failed or an old one is replaced, the LED operating time counter needs to be reset. This is done by selecting „Reset LED module operating time“ within the „Reset“ menu.

CLM and CSM visualisation

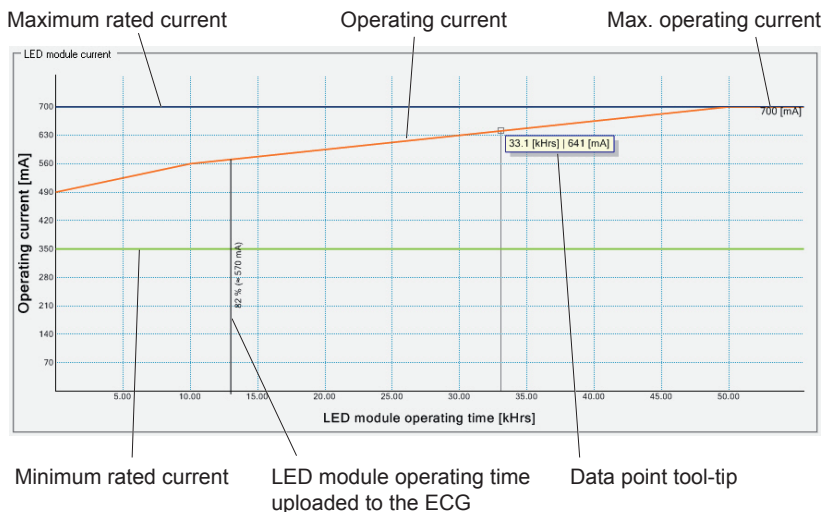

Note:

The display of the operating current (orange line) is also taking the Power-on level (set via StepDIM or AstroDIM) into consideration. Thus displays the actual output current at any time, except where the LEDset interface is used to adjust the output current.

Temperature Protection Module (TPM)

TPM allows for a two-way protection of the LED module(s) against too high temperatures:

- Standard (resistor based)
- Flexible (NTC based)

If Standard (resistor based) setting is selected, the OPTOTRONIC® LED power supply starts lowering the output level if the resistance is below the start derating resistance. This linear decreasing (100% to 50%) is carried out until the end derating resistance. The LED module(s) are switched-off once the resistance undershoots the switch off derating resistance and switched on again if the resistance exceeds end derating resistance.

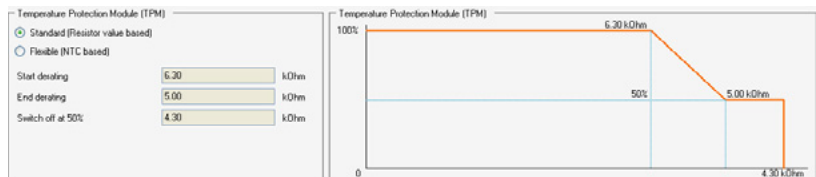
**Note:**

For selecting the correct resistor for each application please refer to the data sheet of the OPTOTRONIC® LED power supply.

If the Flexible (NTC based) setting is selected the temperature protection behaviour can be programmed individually. Therefore the following parameters can be set:

- Sensor type:
The used NTC needs to be selected within the respective drop-down menu.
The following NTC are available in 3DIM Tool:
 - 10k 5% NCP18XH103J03RB (Naming: NCP18XH103J)
 - 15k 3% NCP15XW153E03RC + 390 Ohm (Naming: NCP15XW153E+390)
 - 15k 5% NCP18XW153J03RB (Naming: NCP18XW153J)
 - 47k 3% Epcos B57423V2473H062 (Naming: EPCOS B57423V2473H)
- Start derating in [°C]:
Starting temperature for the linear decreasing of the output level.
- End derating in [°C]:
Temperature until the output level is decreased. Also temperature at which the LED module(s) is switched on again, after it has been switched off for over temperature protection (see next bullet point).

- Shut off temperature in [°C]:
Temperature at which the LED module(s) is switched off for over temperature protection.
- Dim level lower limit in [%]:
Output level at "End derating" temperature. The linear decreasing of the output will be carried out between 100% and the value set within this field.

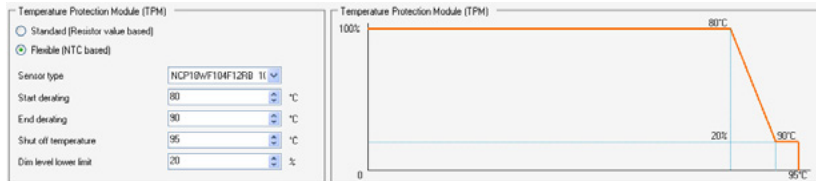

The monitoring feature of 3DIM Tool provides the possibility to double check the TPM settings. (See chapter "Monitoring")

OPTOTRONIC® Config password protection

Since a false setting of the OPTOTRONIC® Config parameters can have severe consequences on the safety of the luminaire, i.e. damaging the LED module, it is possible to lock the "OPTOTRONIC® Config" parameters with a four digit (0000 to 9999) personal identification number (PIN).

This PIN has no influence upon StepDIM or AstroDIM parameters, these can still be reprogrammed without any restrictions.

If the ECG has been locked with a PIN, an upload and therefore changing the OPTOTRONIC® Config parameters only works if the correct PIN has been entered in the PIN field.

Note:

It is only possible to program multiple ECGs if they have the same PIN.

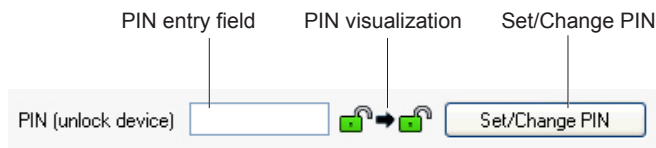

Setting a password

By default the ECG have no password set. The following steps are necessary to lock the ECG with a PIN.

Step	Activity
1	Click "Set/Change PIN" in the OPTOTRONIC® Config tab.
2	Enter the four digit PIN in the "New PIN" field.
3	Repeat the four digit PIN within the "Confirm PIN" field.
4	Click "Set/Change PIN" within the dialog.

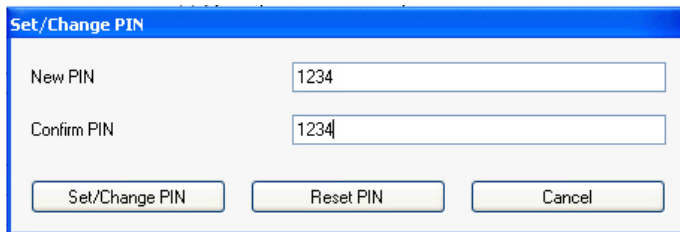

Now OPTOTRONIC® Config parameters within the ECG will be locked with the PIN after the configuration has been uploaded to the ECG.

Changing a password

Note:

The PIN change is valid after uploading the configuration. Therefore the “old” PIN still needs to be used for the upload following the PIN change (see Step 1).

Step	Activity
1	Enter the correct PIN in the “PIN (unlock device)” field.
2	Click “Set/Change PIN” in the OPTOTRONIC® Config tab.
3	Enter the four digit PIN in the “New PIN” field.
4	Repeat the four digit PIN within the “Confirm PIN” field.
5	Click “Set/Change PIN” within the dialog.

Deleting (resetting) a password

Note:

The PIN reset is valid after uploading the configuration. Therefore the “old” PIN still needs to be used for the upload following the PIN reset (see Step 1).

Step	Activity
1	Enter the correct PIN in the “PIN (unlock device)” field.
2	Click “Set/Change PIN” in the OPTOTRONIC® Config tab.
3	Click “Reset PIN” within the dialog.

Password visualisation

The PIN visualisation indicates the status of the ECG before and after the upload. The right lock refers to the state before the upload, the left to the state after the upload.

PIN state within the
ECG before upload

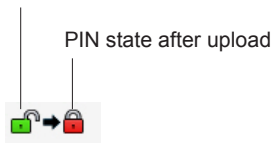

The connected ECG(s) are not locked with a PIN. After the upload they won't be locked with a PIN either.



The connected ECG(s) are not locked with a PIN. After the upload they will be locked with a PIN.



The connected ECG(s) are locked with a PIN. After the upload they will still be locked with a PIN.



The connected ECG(s) are locked with a PIN. After the upload they won't be locked anymore.

Upload/Download

If an upload or download has been triggered, 3DIM Tool first scans for connected 3DIM ECG(s). This scanning process can be tracked within the status bar at the bottom of the software. Once the detection is finished the upload or download is initiated.

Uploading a configuration

Note:

To ensure full compatibility of all configuration files created in the past 3DIM Tool version 2.2.2 or higher needs to be used. All PCs between which configuration files are shared need to have 3DIM Tool version 2.2.2 or higher installed.

An upload only works if:

- The ECG selected in the 3DIM ECG drop-down menu is identical to the connected ECG(s).
- All ECG connected are of the same type, version and PIN.

Step	Activity
1	Click "Transfer" → "Upload to ECG" in the menu bar or  in the toolbar.
2	Within the status bar, the progress of the upload can be tracked.

After the upload is finished, one of three possible confirmation dialogs is displayed.

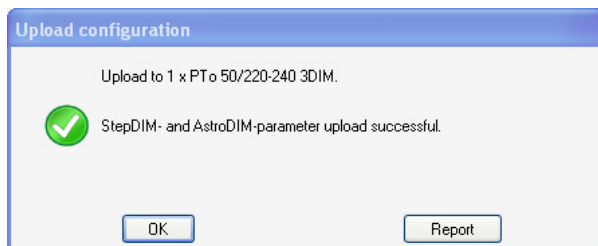

Upload confirmation, ECG without OPTOTRONIC® Config features. 3DIM mode as well as StepDIM- and AstroDIM-parameters uploaded.

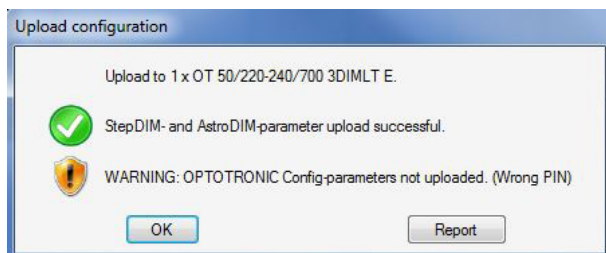

Upload confirmation, ECG with OPTOTRONIC® Config features. Only 3DIM mode as well as StepDIM- and AstroDIM-parameters uploaded. Parameters of the OPTOTRONIC® config features are not uploaded due to the wrong pin.

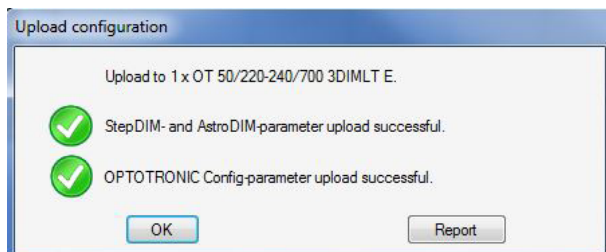

Upload confirmation, ECG with OPTOTRONIC® Config features. All parameters uploaded.

Clicking „OK“ within the confirmation closes the message, clicking „Report“ opens the documentation dialog. (See chapter Report.)

Downloading a configuration

Note:
A download only works if just one ECG is connected.

Step	Activity
1	Click “Transfer” → “Download from ECG” in the menu bar or  in the toolbar.
2	Within the status bar, the progress of the download can be tracked.

After the download is finished, a confirmation dialog is displayed.

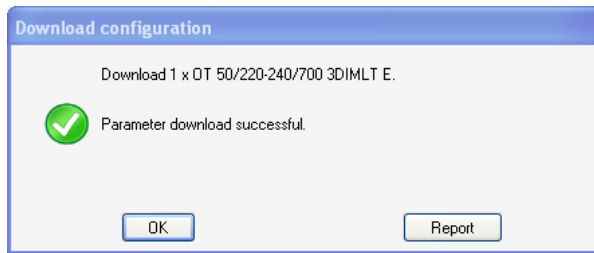

Download confirmation

Clicking „OK“ within the confirmation closes the message, clicking „Report“ opens the documentation dialog. (See chapter Report.)

After the download is finished, the configuration stored within the ECG is visualized in the user interface. If the OPTOTRONIC® Config parameters of the connected ECG are locked with a PIN, the PIN visualisation will be displayed as shown here:



This indicates that a PIN needs to be included into the „PIN (unlock device)“ field to change the OPTOTRONIC® Config parameters of the ECG.

Configuration handling

Saving a configuration

Proceed as follows:

Step	Activity
1	Click “File” → “Save as...” in the menu bar or  in the toolbar.
2	Select a folder via the “Save in” drop-down menu and enter a file name for the configuration. The file type needs to be “OSRAM - 3DIM (*.3dim)”.
3	Click “Save” The selected name appears in the header of the 3DIM Tool.

Loading a configuration

Proceed as follows:

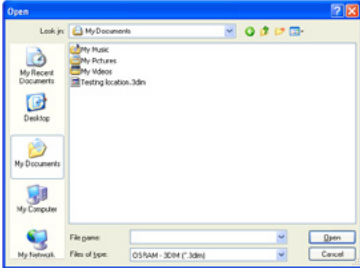
Step	Activity
1	Click "File" → "Load configuration..." in the menu bar or  in the toolbar.
	
2	Select the folder which contains the configuration file via the "Look in:" drop-down menu.
3	Open the configuration by double-clicking. The name of the loaded configuration appears in the header of the 3DIM Tool.



Note:
A configuration can also be loaded by double-clicking the file within the Windows Explorer. Thus the configuration will always be loaded in manufacturing mode (see chapter "Manufacturing mode").

Monitoring

The "Monitoring" window enables a double check of the TPM settings made (i.e. during the luminaire testing) within the "OPTOTRONIC® Config" tab.

Note:
The complete monitoring functionality is only available for OPTOTRONIC® 3DIMLT+ devices. Monitoring only works if just one ECG is connected to the DALI magic hardware interface.

To utilize the monitoring feature of 3DIM Tool proceed as follows:

Step	Activity
1	Connect a 3DIMLT+ device to the DALI magic hardware interface. (See chapter "Hardware installation".)
2	Click "Monitoring" within the menu bar..
3	The monitoring window opens and the ECG is initialized. Should an error message occur, please proceed as indicated within the error message.
4	Monitoring of the connected ECG starts and provides the information as depicted below, a refresh is made every 10 seconds. The status flags appear grey  under normal conditions or red  if the respective state is present.
5	Click "Cancel" to close the monitoring window.

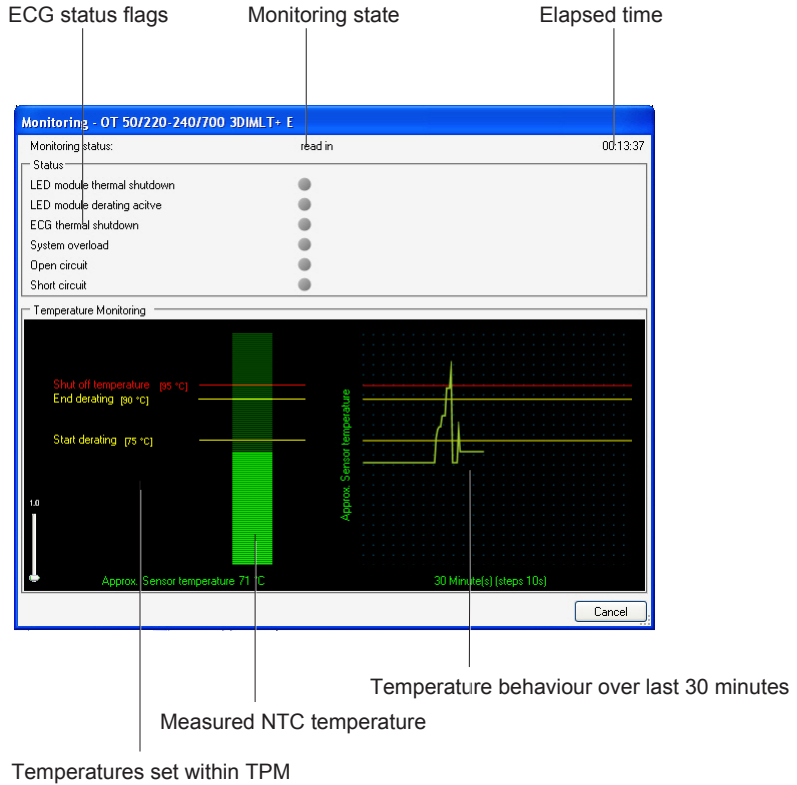

Reset

Reset 3DIM parameters

This reset restores the default configuration of 3DIM mode, StepDIM- and AstroDIM parameters.

Proceed as follows:

Step	Activity
1	Click "Reset" → "Reset 3DIM parameters" in the menu bar.
2	Confirm the warning dialog by clicking "Yes".
3	Restart (disconnecting and reconnecting the power supply) the ECG.

Note:

For a detailed description of the default parameters, please refer to the data / instruction sheet of the utilized ECG.

Delete AstroDIM power-on history

This reset deletes the memory of the operating hours of the last eight nights, which

is used to enable the autonomous dimming. The reset is recommended once the operating location of the ECG changes or if several days lie between reprogramming and deployment.

Proceed as follows:

Step	Activity
1	Click "Reset" → "Delete AstroDIM power-on history" in the menu bar.
2	Confirm the warning dialog by clicking "Yes".
3	Restart (disconnecting and reconnecting the power supply) the ECG.

Reset LED module operating time

This reset deletes the "LED module operating time" counter within the ECG. This feature should be used if the LED module is exchanged with a new one.

Proceed as follows:

Step	Activity
1	Click "Reset" → "Reset LED module operating time" in the menu bar.
2	Confirm the warning dialog by clicking "Yes".
3	Restart (disconnecting and reconnecting the power supply) the ECG.

Note:

Both the CLM look-up table and the checkmark for (de)activating the CLM function are not deleted, this has to be done by correcting the respective configuration.

Settings

Via the settings menu the appearance of the AstroDIM and StepDIM graphs as well as certain input methods can be adjusted. Also the 3DIM Tool can be locked in manufacturing mode.

Display preferences

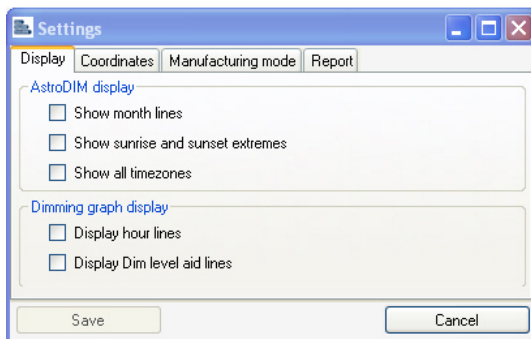

AstroDIM graph display

Within the visualisation of the night lapse (in AstroDIM mode) aid lines as well as

sunrise and sunset times can be displayed.

Proceed as follows:

Step	Activity
1	Click "Settings" in the menu bar.
2	Select respective tick mark within the AstroDIM display frame of the "Display" tab.
3	Click "Save".

Displaying all time zones

By default only one entry per time zone is visible in the time zone drop-down menu of the ECG location dialog. (See chapter "AstroDIM mode" → "Creating a location".) As an option a complete list of time zones can be displayed.

Proceed as follows:

Step	Activity
1	Click "Settings" in the menu bar.
2	(De)activate "Show all time zones".
3	Click "Save".

AstroDIM / StepDIM ECG behaviour display

Depending on personal preferences guidelines for the dimming visualisations can be displayed.

Proceed as follows:

Step	Activity
1	Click "Settings" in the menu bar.
2	Check the checkbox of the respective guideline within the "Display" tab.
3	Click "Save".

Defining coordinate formats

Depending on the source for the ECG operation location in AstroDIM mode, different input methods for coordinates can be defined.

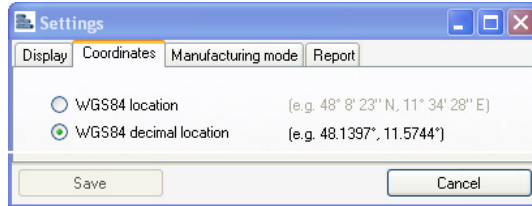

Proceed as follows:

Step	Activity
1	Click "Settings" in the menu bar.
2	Choose decimal or WGS 84 format by setting and removing the tick mark within "Coordinates" tab.
3	Click "Save".

Manufacturing mode

To support quality assurance in (luminaire) production 3DIM Tool has a dedicated "Manufacturing mode". Here only the possibility to upload a predefined configuration remains, no parameter changes can be made. "Manufacturing mode" is started via a dedicated executable, by double-clicking a configuration file (*.3DIM) or manually via the settings menu.

Within the „Manufacturing mode“ tab it is possible to set upload or download reports to be mandatory (Confirmation with auto report generation) or optional (Confirmation without auto report generation). For a detailed description see chapter „Report“.

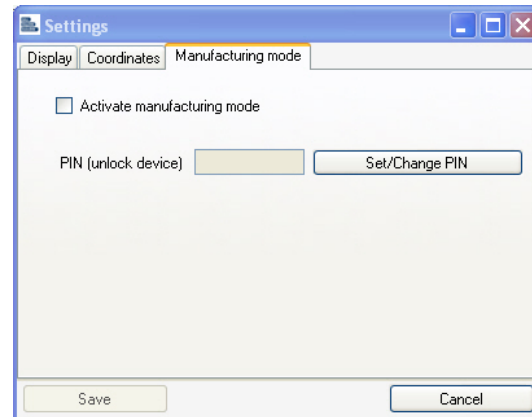

A four digit (0000 to 9999) personal identification number (PIN) can be used to lock 3DIM Tool in "Manufacturing mode". This PIN does not need to be identical to the one protecting the 3DIM Tool OPTOTRONIC® Config parameters.

(De)Activating manufacturing mode

Proceed as follows:

Step	Activity
1	Click "Settings" in the menu bar.
2	Select "Manufacturing mode" tab.
3	(De)Activate manufacturing mode by setting or removing the tick mark.
4	Click "Save".

Note:

If the tick mark for (de)activating manufacturing mode is not selectable, a PIN was used to protect manufacturing mode. Please enter this PIN within the PIN (unlock device) field to regain control over the manufacturing mode (de)activation.

Setting the manufacturing mode PIN

Proceed as follows:

Step	Activity
1	Click "Settings" in the menu bar.
2	Select "Manufacturing mode" tab.
3	Enter current PIN in the PIN (unlock device) field.
4	Click "Set/Change PIN".
5	Enter the new four digit PIN in the "New PIN" field.
6	Repeat the new four digit PIN within the "Confirm PIN" field.
7	Click "Set/Change PIN".
8	Click "Save".

Deleting manufacturing mode PIN

Proceed as follows:

Step	Activity
1	Click "Settings" in the menu bar.
2	Select "Manufacturing mode" tab.
3	Include current PIN in the PIN (unlock device) field.
4	Click "Set/Change PIN".
5	Click "Reset PIN".
6	Click "Save".

Report

Within the "Report" tab the title (i.e. Company XYZ) as well as the items of report chapter 1 "General" can be customized (3DIM File Name, Date / Time and PC operator are fixed). To customize these items proceed as follows:

Step	Activity
1	Click "Settings" within the menu bar

2	Select "Report" tab.
3	Include a report title into the respective field
4	(De)Activate <input checked="" type="checkbox"/> report entries 4 to 6 and include a description for each activated field.
5	Click "Save".

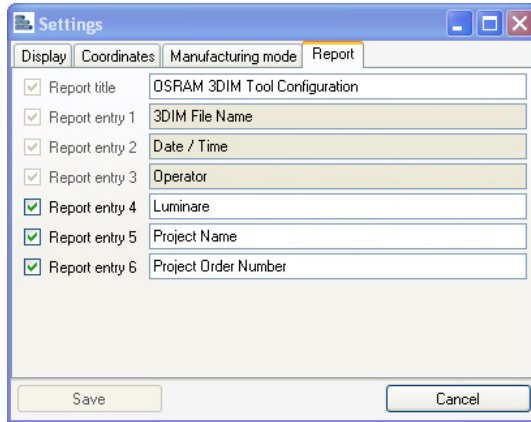

The activated entries will be available for the user to fill in once a report is being created. (See chapter "Report".)

Report

3DIM Tool offers the possibility to create a configuration report. Within this report all used parameters are documented. A report can only be created once a configuration has been uploaded or downloaded.

To create a report, proceed as follows:

Step	Activity
1	Click "Report" in any upload or download confirmation window.
2	The dialog for providing the general information for the report opens. (The available fields correspond to the configurations made within the "Report" tab of the "Settings" menu.)
3	Fill in the empty fields. <div data-bbox="408 534 870 812" data-label="Form"> </div>
4	Click „OK“

Save report Print report

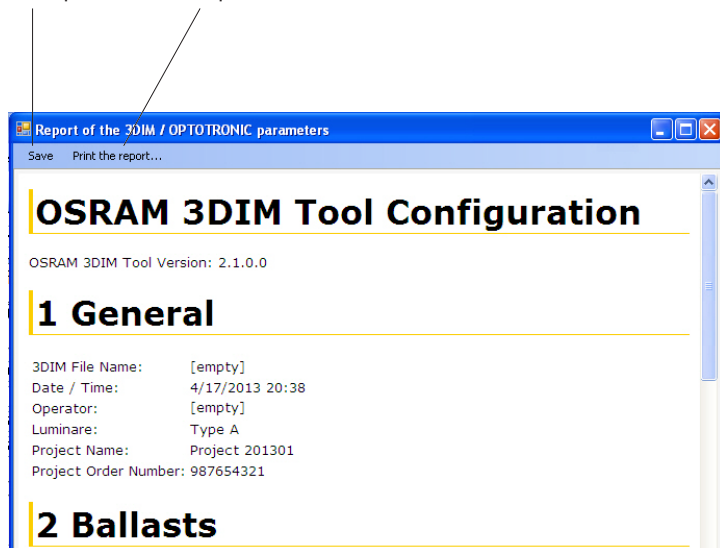

Print report

Reports can be printed via a local or network printer.

Step	Activity
1	Click "Print report..." within the report window.
2	A standard print preview opens up.
3	Set up page and printer acc. to available printing hardware and needed format.
4	Press "Print document" within the print preview.

Save report

Reports can also be saved as *.htm file, to be viewable with a web browser.

Step	Activity
1	Click "Save" within the report window.
2	Select a folder via the "Save in" drop-down menu and enter a file name for the configuration. The file type needs to be "Webpage, HTML only (*.htm;*.html)", encoding is "Unicode".
3	Click "Save".

LOG Files

3DIM Tool creates automatically up to 5.000 LOG files for loading configuration from the ECG (READReport_YY_MM_DD_hh_mm_ss) and transferring data to the ECG (WriteReport_YY_MM_DD_hh_mm_ss). If the maximum number of LOG files are exceeded the older versions would be deleted. Therefore it is recommended to copy and store regularly the files on a separate file server.

The LOG Files are stored under \MY DOCUMENTS\OSRAM\OSRAM 3DIM Tool\LOG\OLD. The LOG File shows the parameters read from or write to the ECG.

old	25.11.2013 08:05	Dateiordner	
2013_11_25-08_05_22_Log	25.11.2013 08:10	Microsoft Office E...	13 KB
ReadReport_2013_11_25-08_06_26	25.11.2013 08:06	HTML-Dokument	7 KB
ReadReport_2013_11_25-08_06_49	25.11.2013 08:06	HTML-Dokument	7 KB
ReadReport_2013_11_25-08_10_36	25.11.2013 08:10	HTML-Dokument	7 KB
WriteReport_2013_11_25-08_08_57	25.11.2013 08:08	HTML-Dokument	7 KB
WriteReport_2013_11_25-08_09_32	25.11.2013 08:09	HTML-Dokument	7 KB
WriteReport_2013_11_25-08_10_12	25.11.2013 08:10	HTML-Dokument	7 KB

Utilizing 3DIM Tool in Production

General

This chapter describes the best practice of using 3DIM Tool during (luminaire) production.

General procedure:

Step	Activity
1	Program ECG(s).
2	Integrate ECG(s) into the luminaire and perform all necessary connections.
3	Perform luminaire test (functionality and safety).

Note:

For LED luminaire manufacturing steps 1 and 2 need to be performed in the correct order and should not be interchanged. Otherwise, the LED module will be driven with maximum possible output current of the ECG (e.g. 700 mA), which could damage the LED module (i.e. in case of a 350 mA module). Only if the current is set via LEDset, it is possible to interchange steps 1 and 2.

Installing 3DIM Tool

Proceed as follows:

Step	Activity
1	Double-click the "Setup OSRAM 3DIM Tool 2.3.1.0.0" ZIP file.
2	Within the ZIP folder, double-click the setup file. The installation wizard appears.
3	Choose "3DIM Tool (manufacturing)" as installation type.

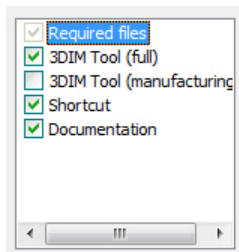

4	Follow the instructions of the installation wizard to complete the setup.
---	---

Programming 3DIM ECG(s)



Note:

To ensure full compatibility of all configuration files created in the past 3DIM Tool version 2.2.2 or higher needs to be used. All PCs between which configuration files are shared need to have 3DIM Tool version 2.2.2 or higher installed.



For the procedure depicted in the following it is necessary to have a prepared "*.3dim" file containing the configuration which shall be utilized.

The upload of a configuration to the ECG(s) can be carried out in two ways.

Uploading a configuration (alternative A):

Step	Activity
1	Double-click the “.3dim” file which shall be used with the ECG(s). 
2	The 3DIM Tool opens (Manufacturing mode), visualizing the selected configuration.
3	Check if the displayed configuration is correct.
4	Click  within the menu bar, to upload the configuration.
5	Depending on the configuration within the settings menu („Manufacturing“ tab) a report can or must be created, by clicking „Report“. (See chapter „Report“.)
6	Finally confirm upload success with “OK”.

Uploading a configuration (alternative B):

Step	Activity
1	Start 3DIM Tool (Manufacturing). 
2	3DIM Tool opens, no particular configuration is selected.
3	Click  and select the configuration which should be utilized.
4	Check if the displayed configuration is correct.
5	Click  within the menu bar to upload the configuration.
6	Depending on the configuration within the settings menu („Manufacturing“ tab) a report can or must be created, by clicking „Report“. (See chapter „Report“.)
7	Finally confirm upload success with “OK”.

Troubleshooting

General error handling

This chapter describes strategies to solve errors which might occur during the utilization of 3DIM Tool.

Should the solutions depicted do not solve the issue please contact the OSRAM customer service center. To improve and speed up the support it is highly recommended to create a diagnose file and to provide this along with your inquiry.

Creating a diagnose file

Step	Activity
1	Select "Help" → "About OSRAM 3DIM Tool..." within the menu bar.
2	Select the "Diagnose" tab.
3	Click "Create diagnose file".
4	Select a folder via the "Save in" drop-down menu and enter a file name. The file type needs to be "*.ZIP".
5	Click "Save".

If a failure is detected it is immediately visualized via a popup message at the top of the user interface.



Note:

In the unlikely event of an error message which is not described within the subchapters below, please proceed as follows:

Step	Activity
1	Confirm error message by clicking "OK".
2	Close 3DIM Tool. (Optionally save the current configuration before closing the software.)
3	Disconnect the DALI magic hardware interface.
4	Restart the PC and reconnect the DALI magic hardware interface. Make sure the DALI magic is connected directly to a USB port of the PC, do not use a USB hub.
5	Restart 3DIM Tool.



The firmware of the controller does not have the required version.

This message appears if the firmware version of the DALI magic utilized is not sufficient to support the range of functions of the 3DIM Tool.

Troubleshooting:

Step	Activity
1	Select "Help" → "About OSRAM 3DIM Tool..." within the menu bar.
2	Select the "Firmware update" tab.
3	Click "Browse".
4	Select the "*.ofw" file (at least v2.18) and click "Open". The latest firmware version is contained in the "Firmware" subdirectory of the root directory.
5	Click "Start firmware update". Confirm the appearing warning message with "Yes".
6	After the update is complete, the progress bar stops and the following message appears: <div style="border: 1px solid black; padding: 5px; margin: 5px 0;"> Send firmware to device Compare checksum Checksum ok Start update DO NOT unplug the device Reset device </div> All LEDs of the DALI magic are switched off.
7	Disconnect the USB connection between the DALI magic and PC.
8	Confirm error message with "OK", possibly a second error message needs to be confirmed also.
9	Close 3DIM Tool.
10	Reconnect the DALI magic to the PC and restart 3DIM Tool.

More than one DALI magic connected.

This occurs if two or more DALI magic are connected to the PC.

Troubleshooting:

Step	Activity
1	Disconnect the USB connection of the DALI magic which is not utilized for programming the ECG(s).
2	Confirm error message with "OK".

Upload failed. The connected ECG differs from the 3DIM Tool selection.

This occurs if 3DIM ECG selected within the "3DIM ECG" drop-down menu does not match with the connected ECG(s).

Troubleshooting:

Step	Activity
1	Check which ECG type has been connected to the DALI magic.
2	Select the same ECG type within the "3DIM ECG" drop-down menu.
3	Double-check if the current configuration is suitable for the utilized ECG.
4	Confirm error message with "OK".
5	Repeat the upload process.

Communication failures

The following communication errors can occur:

- Download failed
- Upload failed
- Reset failed
- Reading GTIN failed
- Addressing of ballasts failed
- Searching for ballasts failed
- Check Connection (DALI® / mains)

Troubleshooting:

Step	Activity
1	Check ECG power-supply.
2	Check DALI® wiring between ECG(s) and DALI magic
3	Disconnect and reconnect USB connection between DALI magic and PC.
4	Make sure the connected ECG(s) and the ECG selected within the "3DIM ECG" drop-down menu match.
5	Confirm error message with "OK".
6	Repeat the upload, download or reset process.

Unknown ECG

Only OSRAM 3DIM ECG can be programmed with the 3DIM Tool. If another kind of ECG(s) is connected, the 3DIM Tool will stop the upload, download or reset.

Troubleshooting:

Step	Activity
1	Disconnect ECG(s).
2	Confirm error message with "OK".
3	Only proceed using 3DIM Tool with OSRAM 3DIM ECG(s).

More than X device(s) connected.

3DIM Tool stops the current process, if too many ECG(s) for the initiated process are connected.

Depending on the chosen DALI magic power-supply either a maximum of 4 (internal power-supply) or 64 (external power-supply) devices can be programmed simultaneously.

A configuration download can only be triggered if just one 3DIM ECG is connected.

Troubleshooting:

Step	Activity
1	Upload: Disconnect all ECGs except 4 (internal power-supply) respective 64 (external power-supply). Download: Disconnect all ECGs except one.
2	Confirm error message with "OK".
3	Repeat upload, download or reset.

DALI short circuit.

This failure has two possible reasons, either a short circuit within the DALI® line or too many connected ECGs.

To resolve this issue proceed as follows:

Step	Activity
1	Check DALI® wiring and remove potential short circuits between the two DALI® lines.
2	Check if only the allowed amount of ECGs is connected: <ul style="list-style-type: none"> • 4 if the internal power-supply of the DALI magic is used • 64 if the external power-supply is used
3	Disconnect and reconnect the DALI magic USB connection.
4	Confirm error message with "OK".

OSRAM GmbH

Steinerne Furt 62
86167 Augsburg, Germany
www.osram.com

