

# Indy H20

1. Unpack the luminaire and check for damage. If visible damage is present, contact your Ahlsell outlet.
2. Install the luminaire suspended by suitable chain or wire. Minimum distance from illuminated surface is 0,3m. Maximum recommended mounting height 12m.
3. Connect the pre-connected cable to a suitable connection point with proper strain relief.
4. Switch on power and check function. If the luminaire is not working, check that correct voltage is present at the connection point. Faulty luminaire should be returned to your Ahlsell outlet..

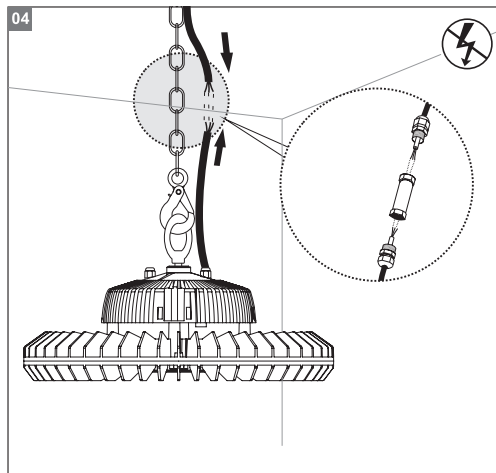

1. This luminaire shall only be installed by qualified electrician.
2. The light source cannot be replaced.
3. The connection cable cannot be replaced.
4. Ground wire must be connected.
5. The luminaire must be connected to the stated voltage.
6. Do not use chemicals or corrosive cleaner.
7. The minimum distance from the luminaire to illuminated objects is 0,3m.
8. The glass cannot be replaced.

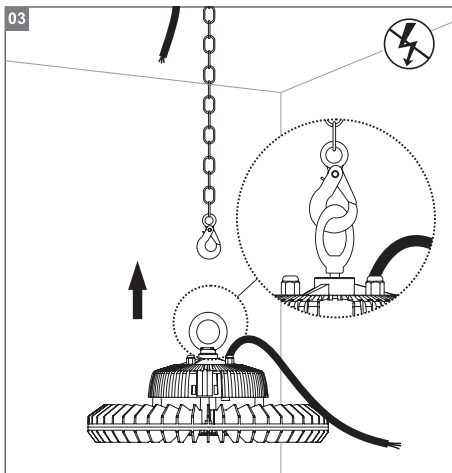
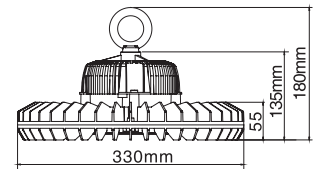
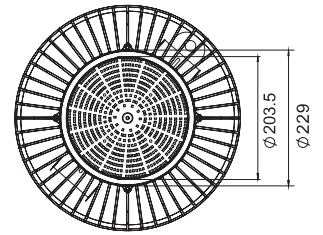
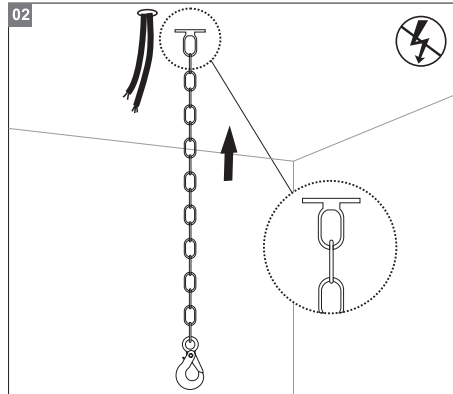
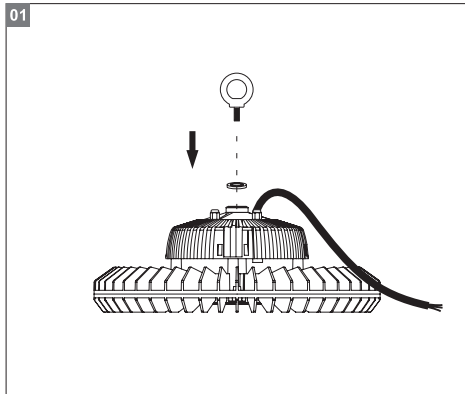
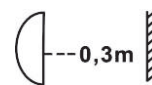

# Indy H20

1. Packa upp armaturen och kontrollera att den är oskadd. Är armaturen skadad, kontakta din Ahlsell-butik.
2. Installera armaturen pendlad i lämplig kedja eller vajer. Minsta avstånd till belyst yta 30 centimeter. Högsta rekommenderade höjd över golv 12 meter.
3. Anslut den förmonterade kabeln till lämplig anslutningspunkt. Säkerställ dragavlastning.
4. Slå till strömmen och utför funktionskontroll. Om armaturen inte fungerar, kontrollera att den är ansluten till rätt spänning. Kvarstår felet, reklamera till din Ahlsell-butik.

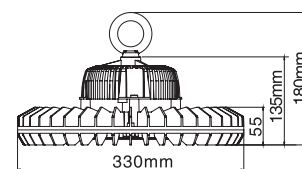
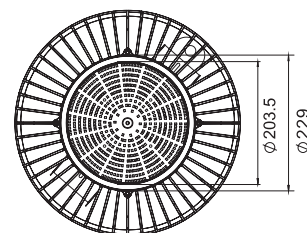
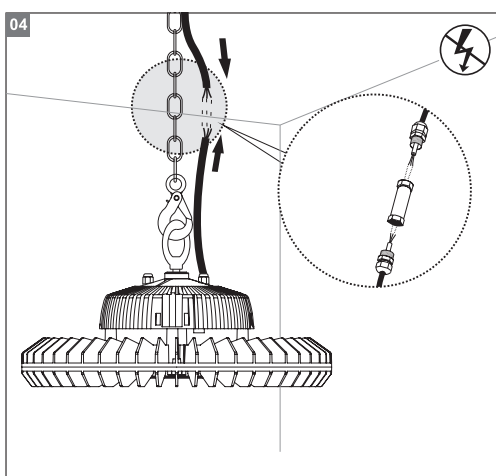
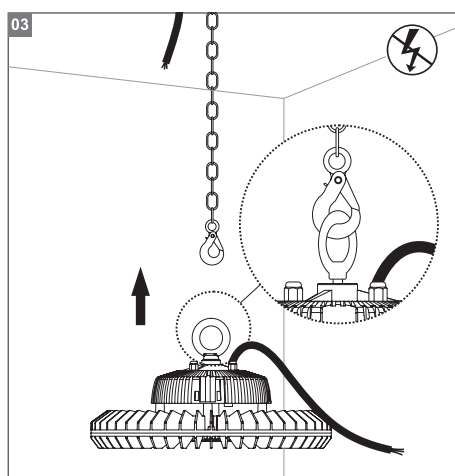
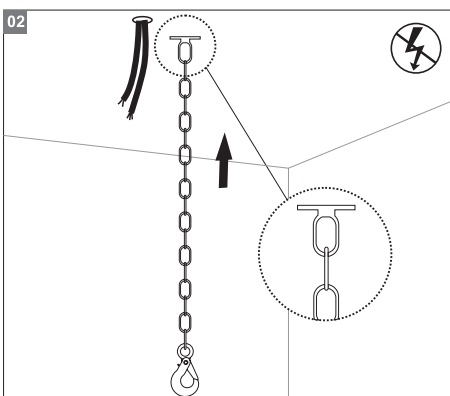
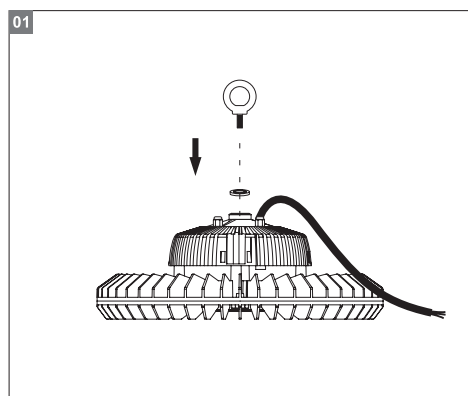

1. Armaturen ska installeras av behörig elektriker.
2. Ljuskällan får ej bytas.
3. Den förmonterade kabeln får ej bytas.
4. Skyddsledare ska anslutas.
5. Armaturen ska anslutas till angiven spänning.
6. Använd ej rengöringsmedel på armaturen.
7. Minsta avstånd från belyst yta 0,3 m.
8. Glaset får ej bytas.

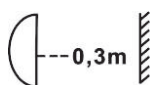

# Indy H20

1. Pakk ut armaturen, og kontroller at den er uskadd. Hvis armaturen er skadet, ta kontakt med Ahlsell-butikken.
2. Monter armaturen som er pendlet, i egnet kjede eller vaier. Minimumsavstand til opplyst overflate 30 centimeter. Maksimal anbefalt høyde over gulv 12 meter.
3. Koble den forhåndsmonterte kabelen til et egnet tilkoblingspunkt. Sørg for trekkavlastning.
4. Slå på strømmen, og utfør funksjonskontroll. Hvis armaturen ikke fungerer, må det kontrolleres at den er koblet til riktig spenning. Hvis feilen vedvarer, kan du klage til Ahlsell-butikken.

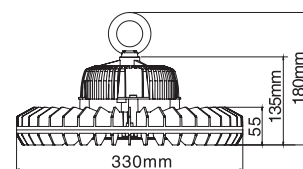
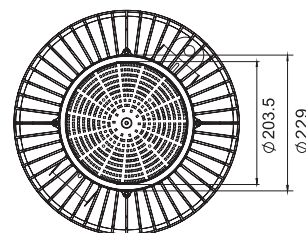
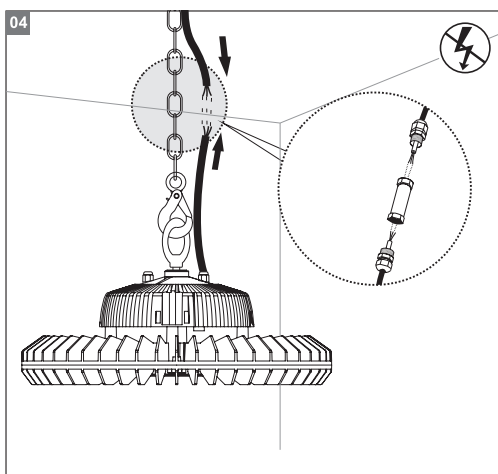
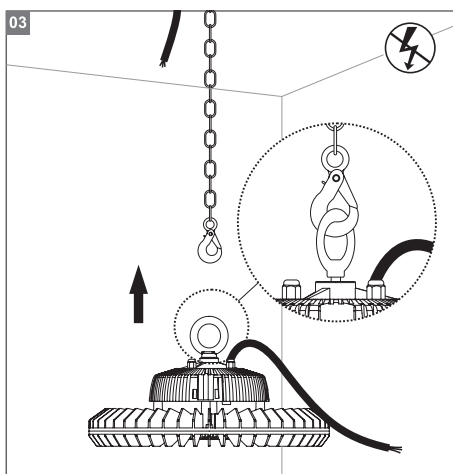
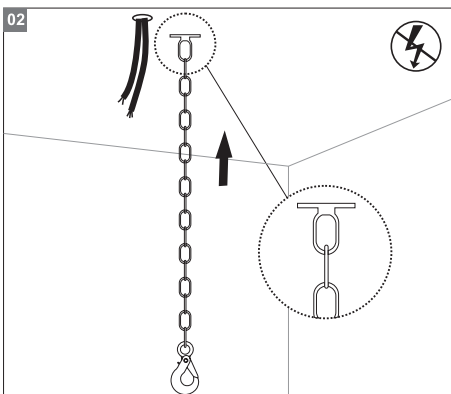
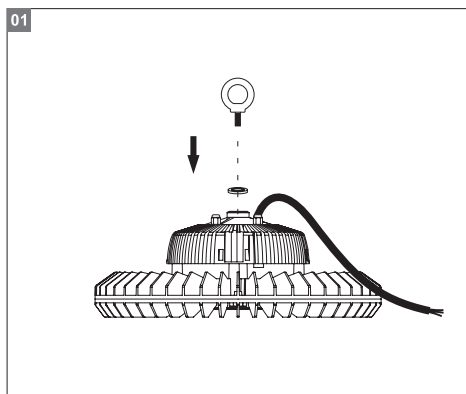

1. Armaturen må installeres av en kvalifisert elektriker.
2. Lyskilden må ikke skiftes ut.
3. Den forhåndsmonterte kabelen må ikke skiftes ut.
4. Jordledning skal kobles til.
5. Armaturen skal kobles til den angitte spenningen.
6. Ikke bruk rengjøringsmidler på armaturen.
7. Minimum avstand fra opplyst overflate 0,3 m.
8. Glasset må ikke skiftes ut.

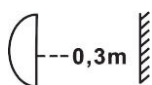

# Indy H20

1. Pura valaisin pakkauksesta ja tarkista, ettei se ole vaurioitunut. Jos valaisin on vaurioitunut, ota yhteyttä Ahlsell-myymälään.
2. Asenna valaisin roikkumaan sopivaan ketjuun tai vaijeriin. Vähimmäisetäisyys valaistavaan pintaan on 30 senttimetriä. Suurin suositeltu korkeus on 12 metriä lattiasta.
3. Liitä esiasennettu johto sopivaan liitäntäpistokkeeseen. Varmista vedonpoistaja.
4. Kytke virta päälle ja tarkasta toiminta. Jos valaisin ei toimi, tarkista, että se on liitetty oikeaan jännitteeseen. Jos vika ei korjaannu, tee tuotteesta reklamaatio Ahlsell-myymälesi.

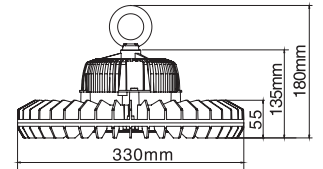
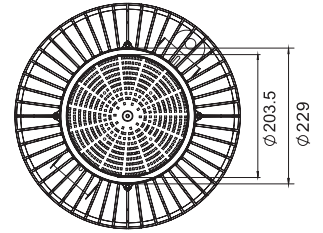
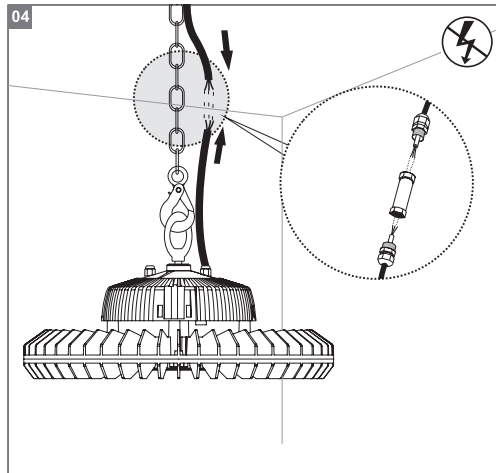
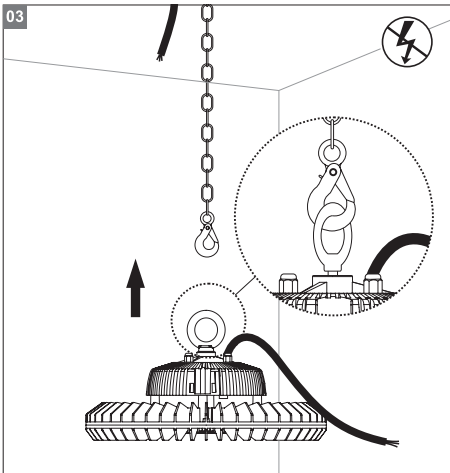
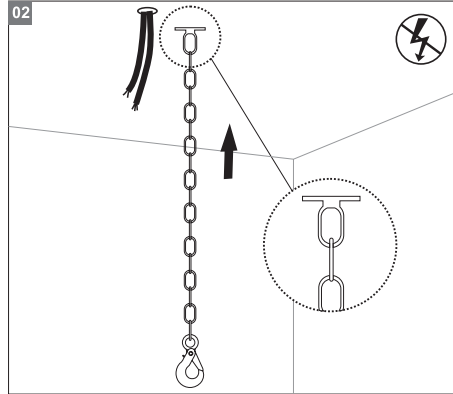
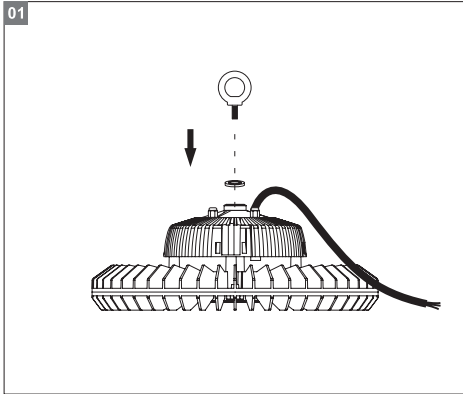

1. Valaisimen saa asentaa vain pätevä sähköasentaja.
2. Älä vaihda valonlähdettä.
3. Esiasennettua johtoa ei saa vaihtaa.
4. Suojajohtimet on kytkettävä.
5. Valaisin on liitettävä ilmoitettuun jännitteeseen.
6. Älä käytä valaisimen puhdistamiseen puhdistusaineita.
7. Minimietäisyys valaistavasta pinnasta 0,3 m.
8. Älä vaihda lasia.

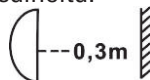

## Valmistuttaja: Ahlsell

Ahlsell AB  
117 98 Tukholma  
Ruotsi  
www.ahlsell.fi

# a-collection